

Installation guide

Thermostatic expansion valves

Type TE 5, TE 12, TE 20 and TE 55

067R9608

067R9608

<p>Refrigerants: See product label For all approved list of refrigerants, visit http://store.danfoss.com/</p>	<p>Max. working pressure PS / MWP: 28 bar / 400 psig</p>	<p>Max. test pressure P_{test} : 32 bar / 465 psig</p>																							
<p>Solder</p> <p>Min. 5% Ag</p>	<p>Danfoss 67B22.10</p>	<p>Flange</p> <p>45 ± 5 Nm / 33.2 ± 3.7 ft-lbs</p>																							
<p>Danfoss 67B26.20</p> <p>Allen key M6</p>	<table border="1"> <thead> <tr> <th rowspan="2">Type</th> <th colspan="3">Torque ± 5%</th> </tr> <tr> <th>Nm</th> <th>kpm</th> <th>ft-lbs</th> </tr> </thead> <tbody> <tr> <td>TE 5</td> <td>10</td> <td>1.1</td> <td>7.4</td> </tr> <tr> <td>TE 12</td> <td>13</td> <td>1.4</td> <td>9.6</td> </tr> <tr> <td>TE 20</td> <td>13</td> <td>1.4</td> <td>9.6</td> </tr> <tr> <td>TE 55</td> <td>15</td> <td>1.6</td> <td>11.1</td> </tr> </tbody> </table>	Type	Torque ± 5%			Nm	kpm	ft-lbs	TE 5	10	1.1	7.4	TE 12	13	1.4	9.6	TE 20	13	1.4	9.6	TE 55	15	1.6	11.1	<p>Danfoss 67B22.10</p>
Type	Torque ± 5%																								
	Nm	kpm	ft-lbs																						
TE 5	10	1.1	7.4																						
TE 12	13	1.4	9.6																						
TE 20	13	1.4	9.6																						
TE 55	15	1.6	11.1																						
<p>Danfoss 67B25.20</p>	<p>Danfoss 67B25.20</p>	<p>Danfoss 67B21.10</p> <ul style="list-style-type: none"> 1/2 - 5/8 in. (12-16mm) 3/4 - 7/8 in. (18-22mm) 1 - 1 3/8 in. (25-35mm) 																							
<p>Danfoss 67B21.10</p> <p>Torx T25 Max. 4 Nm / 3 ft-lbs</p>	<p>Danfoss 67B23.20</p> <ul style="list-style-type: none"> ✓ $t_2 > t_1$ ✗ $t_2 = t_1$ ✗ $t_2 < t_1$ <p>t_2 MOP</p>	<p>Danfoss 67B23.20</p> <p>Superheat = $t_1 - t_s$</p> <p>$p_s \sim t_s$</p>																							

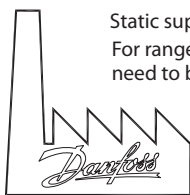

Static superheat = 4 K / 7.2 °F
For range B, the static superheat need to be adjusted

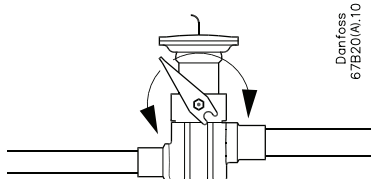

Danfoss
67B20(A).10

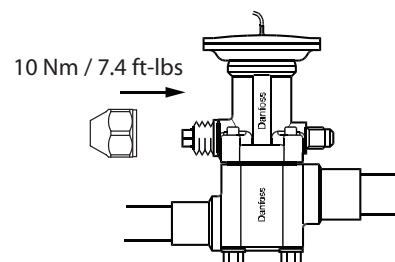

Temperature ranges:

Range N: -40 – 10 °C / -40 – 50 °F
Range NL: -40 – -5 °C / -40 – 25 °F
Range NM: -40 – -15 °C / -40 – 5 °F
Range B: -60 – -25 °C / -75 – -15 °F

$\Delta SH / 360^\circ$ \ominus \oplus

TE 5, TE 12	N, NL, NM	~0.5 K / 1 °F
	B	~1.5 K / 3 °F
TE 20, TE 55	N, NL, NM	~0.5 K / 1 °F
	B	~1 K / 2 °F

TE 5

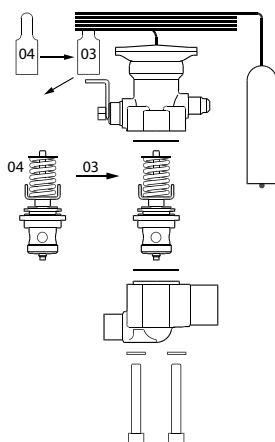

TE 12 / TE 20

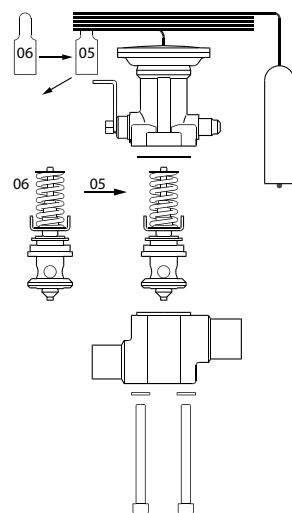

TE 55

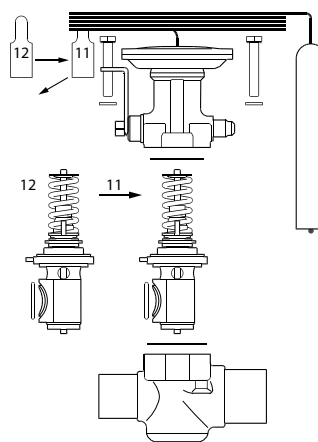

Danfoss
67B2.20

Cross reference				Rated capacity ²⁾																	
Type	Code no.	Orifice no.	Old code no.	[kW]								[TR]									
				R407F	R407A	R448A/ R449A	R452A	R404A/ R507	R22	R513A	R134a	R407C	R407F	R407A	R448A/ R449A	R452A	R404A/ R507	R22	R513A	R134a	R407C
TE 5	067B2788	0.5	–	11	9	9	7	7	9	5	5	11	3	2.5	2.5	2	2	2.5	1.5	1.5	3
	067B2789	01	067B2089 067B2005 ¹⁾	18	18	18	14	14	16	11	11	18	5	5	5	4	4	4.5	3	3	5
	067B2790	02	067B2090	28	25	25	21	19	25	14	16	25	8	7	7	6	5.5	7	4	4.5	7
	067B2791	03	067B2091 067B2006 ¹⁾	35	32	32	28	25	32	18	21	32	10	9	9	8	7	9	5	6	9
	067B2792	04	067B2092 067B2007 ¹⁾	46	42	46	39	35	42	25	28	46	13	12	13	11	10	12	7	8	13
TE 12	067B2708	05	067B2008	70	56	53	46	49	56	30	35	53	20	16	15	13	14	16	8.5	10	15
	067B2709	06	–	95	74	70	63	63	74	39	49	74	27	21	20	18	18	21	11	14	21
	067B2710	07	–	113	95	91	81	81	95	49	63	91	32	27	26	23	23	27	14	18	26
TE 20	067B2771	08	067B2172 067B2170 067B2175	141	127	123	84	84	127	74	77	116	40	36	35	24	24	36	21	22	33
	067B2773	09	–	158	148	141	98	102	148	81	91	134	45	42	40	28	29	42	23	26	38
TE 55	067G2705	9B	–	123	109	113	84	84	113	70	74	109	35	31	32	24	24	32	20	21	31
	067G2701	10	–	172	165	155	116	127	169	98	109	162	49	47	44	33	36	48	28	31	46
	067G2704	11	067G2005 067G2001 067G2011	186	183	169	127	137	183	106	120	176	53	52	48	36	39	52	30	34	50
	067G2707	12	–	208	200	186	141	151	200	116	134	190	59	57	53	40	43	57	33	38	54
	067G2710	13	067G2006 067G2002 067G2012	250	243	225	172	183	246	144	165	232	71	69	64	49	52	70	41	47	66

¹⁾ Part of old TE 12 valve assembly. Need to change to TE 5 valve body and element for replacement

²⁾ The rated capacity is based on:

- Evaporating temperature $t_e = 4.4 \text{ °C} / 40 \text{ °F}$
- Condensing temperature $t_c = 38 \text{ °C} / 100 \text{ °F}$
- Refrigerant temperature ahead of valve $t_1 = 37 \text{ °C} / 98 \text{ °F}$