

# BOCK® FK20

## Operating guide

FK20/120 N  
FK20/120 K  
FK20/120 TK

FK20/145 N  
FK20/145 K  
FK20/145 TK

FK20/170 N  
FK20/170 K  
FK20/170 TK

FKX20/120 N  
FKX20/120 K  
FKX20/120 TK

FKX20/145 N  
FKX20/145 K  
FKX20/145 TK

FKX20/170 N  
FKX20/170 K  
FKX20/170 TK

# About these instructions

Read these instructions before assembly and before using the compressor. This will avoid misunderstandings and prevent damage. Improper assembly and use of the compressor can lead to serious or fatal injury.

Observe the safety instructions contained in these instructions.

These instructions must be passed onto the end customer along with the unit in which the compressor is installed.

The safety advice, which is contained in these instructions for assembly, and which is relevant for regular operation and maintenance, must be forwarded by the manufacturer in his own documents to the operator of the entire system. It must also be ensured, that personnel working in daily operation with the compressor have access to important information such as safety and warning advice about the compressor. Such persons must read the safety advice and have understood it. Bock assumes no liability for any damage arising from non-compliance.

# Contents





Page

<b>1</b>	<b>Safety</b>	<b>4</b>
1.1	Identification of safety instructions	
1.2	Qualifications required of personnel	
1.3	Danger to life and limb in the event of faults during operation	
1.4	General safety instructions	
1.5	Intended use	
<b>2</b>	<b>Product description</b>	<b>6</b>
2.1	Brief description	
2.2	Name plate	
2.3	Type key	
<b>3</b>	<b>Areas of application</b>	<b>8</b>
3.1	Refrigerants	
3.2	Oil charge	
3.3	Limits of application	
<b>4</b>	<b>Compressor assembly</b>	<b>9</b>
4.1	Setting up	
4.2	Maximum permissible inclination	
4.3	V-belt drive	
4.4	Main bearing load	
4.5	Electromagnetic clutch assembly	
4.6	Pipe connections	
4.7	Pipes	
4.8	Operating the shut-off valves	
4.9	Operating mode of the lockable service connections	
4.10	Suction pipe filter	
<b>5</b>	<b>Commissioning</b>	<b>13</b>
5.1	Preparations for start-up	
5.2	Pressure strength test	
5.3	Leak test	
5.4	Evacuation	
5.5	Refrigerant charge	
5.6	Shaft seal	
5.6.1	Notes on replacing the shaft seal	
5.7	Avoiding liquid shocks	
<b>6</b>	<b>Maintenance</b>	<b>16</b>
6.1	Preparation	
6.2	Work to be carried out	
6.3	Recommended spare parts/accessories	
6.4	Lubricants / Oils	
6.5	Decommissioning	
6.6	Valve plate, TK version	
<b>7</b>	<b>Accessories</b>	<b>18</b>
7.1	Thermal protection thermostat	
<b>8</b>	<b>Technical Data</b>	<b>19</b>
<b>9</b>	<b>Dimensions and Connections</b>	<b>20</b>
<b>10</b>	<b>Declaration of incorporation</b>	<b>22</b>

GB

# 1| Safety

## 1.1 Identification of safety instructions:

	<b>DANGER!</b> Indicates a dangerous situation which, if not avoided, will cause immediate fatal or serious injury.
	<b>WARNING!</b> Indicates a dangerous situation which, if not avoided, may cause fatal or serious injury.
	<b>CAUTION!</b> Indicates a dangerous situation which, if not avoided, may cause fairly severe or minor injury.
	<b>ATTENTION!</b> Indicates a situation which, if not avoided, may cause property damage.
	<b>INFO!</b> Important information or tips on simplifying work.

GB

## 1.2 Qualifications required of personnel

	<b>WARNING!</b> Inadequately qualified personnel poses the risk of accidents, the consequence being serious or fatal injury. Work on compressors is therefore reserved for personnel with the qualifications listed below: <ul style="list-style-type: none"><li>• For example, a refrigeration technician, refrigeration mechatronic engineer. As well as professions with comparable training, which enables personnel to assemble, install, maintain and repair refrigeration and air-conditioning systems. Personnel must be capable of assessing the work to be carried out and recognising any potential dangers.</li></ul>
---	---

# 1 | Safety

## 1.3 Danger to life and limb in the event of faults during operation



**WARNING!** If a compressor continues to be operated during extreme running noise and/or a sharp reduction in refrigerating capacity, there is the danger of further events occurring, such as the fracture of the housing wall. If people are standing in the immediate surroundings, there is the risk of severe injury or even death from flying parts.

- In the event of extreme running noise, switch the compressor off immediately.
- If there is a sharp reduction in refrigerating capacity, switch the compressor off immediately.
- Secure the compressor against being switched on again.
- In such cases do not continue to operate the compressor under any circumstances.

## 1.4 General safety instructions



**DANGER!** • Refrigerating compressors are pressurised machines and as such call for heightened caution and care in handling. The maximum permissible overpressure must not be exceeded, even for testing purposes.



**WARNING!** • Risk of burns! Depending on the operating conditions, surface temperatures of over 60 °C on the discharge side or below 0 °C on the suction side can be reached.

GB

## 1.5 Intended use

These assembly instructions describe the standard version of the FK20 manufactured by Bock. The compressor is intended for use in refrigeration systems in compliance with the limits of application. Only the refrigerant specified in these instructions may be used.

**Any other use of the compressor is prohibited!**

The Bock refrigerating compressor named in the title is intended for installation in a machine (with in the EU according to the EU Directives 2006/42/EC Machinery Directive, 2014/68/EU Pressure Equipment Directive).

Commissioning is permissible only if the compressor has been installed in accordance with these assembly instructions and the entire system into which it is integrated has been inspected and approved in accordance with legal regulations.

## 2| Product description

### 2.1 Brief description

Three different designs are available for various ranges of application:

- > for air-conditioning **the K Design**
- > for air-conditioning or normal cooling **the N Design**
- > for deep freezing **the TK Design**

The differences lie mainly in the valve plate tooling which is adapted to each application range where operational safety and efficiency are concerned.

- Compact two-cylinder compressor in single row.
- Three capacity ranges.
- Lightweight aluminum design.
- Lubricating oil pump with oil pressure relief valve independent of rotational direction.
- Variable connection and fixing options.

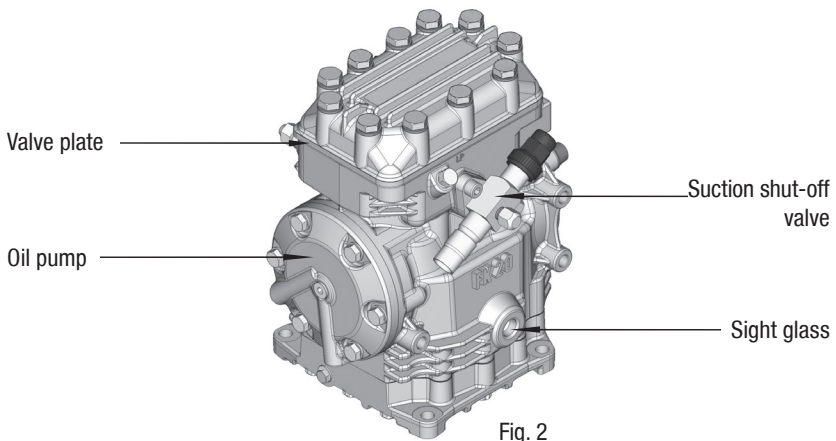
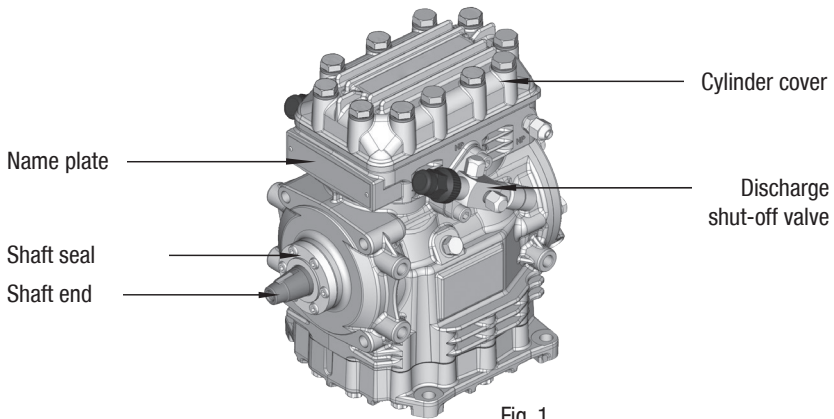

Dimension and connection values can be found in Chapter 9

## 2| Product description

### 2.2 Name plate (example)

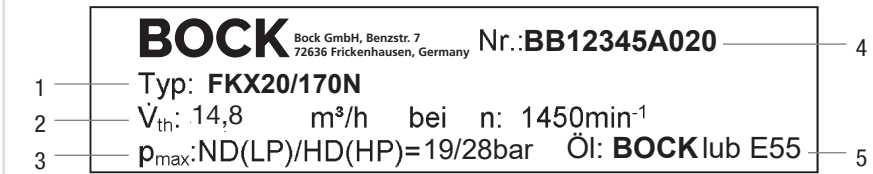

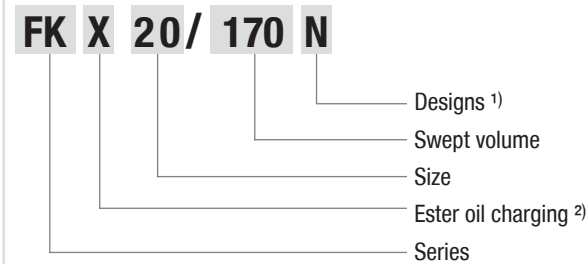

Fig. 3

1	Type designation	4	Machine number
2	Displacement at 1450 rpm	5	Factory-filled oil type
3	LP: Max. permissible operating pressure (g) Low pressure side HP: Max. permissible operating pressure (g) High pressure side	 <b>Observe the limits of application diagrams!</b>	

### 2.3 Type key (example)



- 1) K - specially for air-conditioning
- N - specially for air-conditioning or normal cooling
- TK - specially for deep freezing
- 2) X - Ester oil charging (HFC refrigerant, e.g. R134a, R407C)

## 3| Areas of application

### 3.1 Refrigerants

- HFKW / HFC: R134a, R404A/R507, R407C
- HFCKW / HCFC: R22

### 3.2 Oil charge

- The compressors are factory-filled with the following oil type:
  - for R134a, R404A/R507, R407C **BOCK**lub E55
  - for R22 **BOCK**lub A46

Compressors with ester oil charge (**BOCK**lub E55) are marked with an X in the type designation (e.g. FKX20/170 N).



**INFO!**

For recharging, we recommend the above oil types. See chapter 6.4.

### 3.3 Limits of application



**ATTENTION!** • Compressor operation is possible within the operating limits. These can be found in Bock compressor selection tool (VAP) under [vap.bock.de](http://vap.bock.de). Observe the information given there.

- Max. permissible discharge end temperature: 140°C
- Permissible ambient temperature: (-20°C) - (+100°C)
- Max. permissible switching frequency: 12 x /h
- A minimum running time of 2 min. at equilibrium (continuous operation) must be achieved.

- Avoid continuous operation near the threshold. Should the compressor happen to be used near the thresholds, we recommend the use of a thermal protection thermostat (Accessories, Chap. 7).
- When operating in the vacuum range, there is a danger of air entering on the suction side. This can cause chemical reactions, a pressure rise in the condenser and an elevated compressed-gas temperature. Prevent the ingress of air at all costs!

**Max. permissible operating pressure (g) high-pressure side (HP):**  
28 bar

# 4| Compressor assembly



## INFO!

New compressors are factory-filled with inert gas. Leave this service charge in the compressor for as long as possible and prevent the ingress of air.

Check the compressor for transport damage before starting any work.

### 4.1 Setting up

- Storage at (-40°C) - (+100°C), maximum permissible relative Humidity 10% - 95%, no condensation
- Fittings (e.g. pipe holders, additional units etc.) on the compressor are permissible only following consultation with Bock.
- Setup on an even surface or frame with sufficient load-bearing capacity. The compressor can be fastened as follows:
  - using the 4 drill holes on the baseplate
  - using the 3 side M10 tapped blind holes on the left or right of the compressor housing
  - using the 4 M10 tapped blind holes on the front of the compressor housing.
- Correct setup of the compressor and mounting of the belt drive are decisive for running comfort, operating safety and the service life of the compressor.

### 4.2 Maximum permissible inclination



**ATTENTION!** Poor lubrication can damage the compressor. Respect the stated values.

GB

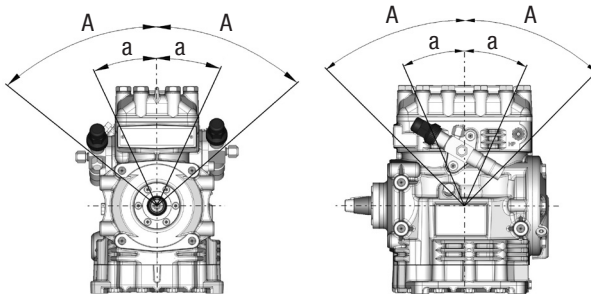

A	max. 30°, max. 2 minutes
a	max. 15°, continuous operation

Fig. 4

# 4| Compressor assembly

## 4.3 V-belt drive



**ATTENTION!** Inappropriately designed belt drives, especially belt knocking (offsets, inclinations) or excessive tensioning forces can cause compressor damage! Make sure that the drive belt is designed correctly, e.g. by using tensioners and selecting the belt profile and the belt length.

## 4.4 Main bearing load

To prevent the belt drive overloading the compressor main bearing, ensure that:

- The engagement force applied by the belt tension (see Fig. 5) must not exceed  $F_{\text{max per.}} = 600 \text{ N}$ .
- If the force engagement point shifts to the right (see Fig. 5, small point), the force  $F_{\text{max per.}}$  reduces as per the following formula:

$$F_{\text{max per.}} = \frac{30 \text{ kNmm}}{(50 \text{ mm} + L_1 [\text{mm}])}$$

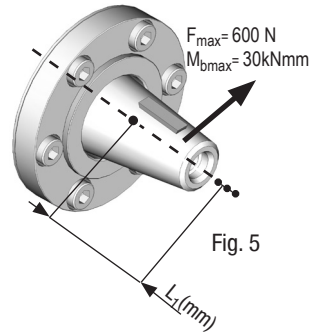

Fig. 5

GB

## 4.5 Electromagnetic clutch assembly

The following description applies for an electromagnetic clutch secured to a shaft.

- To absorb the magnetic field of the electromagnetic clutch, the sliding ring lid has a snug fit  $\varnothing 38 \text{ h8}$  (see Fig. 6).
- To connect the magnetic field, remove the marked Allen head screws of the sliding ring lid (see Fig. 7).
- Slide the magnetic field to a snug-fit and fasten using the three M5 x 20 cheese head screws provided (Fig. 7). Screw torque = 9 Nm.
- Further assembly of the electromagnetic clutch according to the clutch manufacturer.

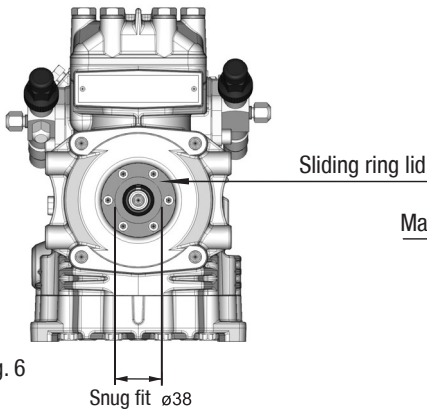

Fig. 6

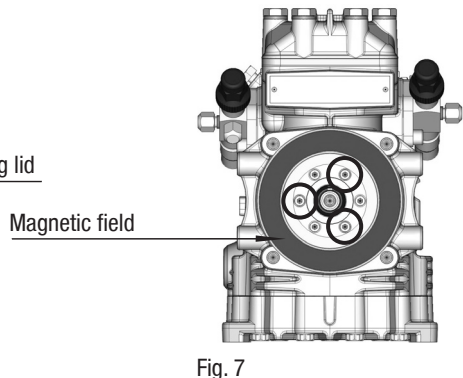

Fig. 7

# 4| Compressor assembly

## 4.6 Pipe connections

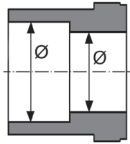

Fig. 8: Stepped internal diameters

- The **pipe connections**, if installed, have graduated inside diameters so that pipes in the common millimeter and inch dimensions can be used.
- The connection diameters of the shut-off valves are designed for maximum compressor output. **The required pipe cross-section must be matched to the capacity. The same applies for non-return valves.**



**ATTENTION!** Overheating can damage the valve.  
Solder only using inert gas to inhibit oxidation products.

## 4.7 Pipes

- Pipes and system components must be clean and dry inside and free of scale, swarf and layers of rust and phosphate. Only use air-tight parts.
- Lay pipes correctly. Suitable vibration compensators must be provided to prevent pipes being cracked and broken by severe vibrations.
- Ensure a proper oil return.
- Keep pressure losses to an absolute minimum.

## 4.8 Operating the shut-off valves

- Before opening or closing the shut-off valve, release the valve spindle seal by approx.  $\frac{1}{4}$  of a turn counter-clockwise.
- After activating the shut-off valve, re-tighten the adjustable valve spindle seal clockwise.

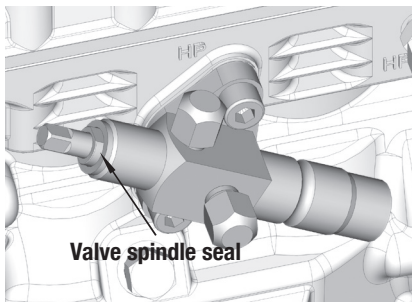

Fig. 9

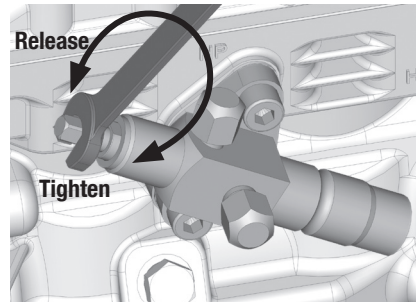
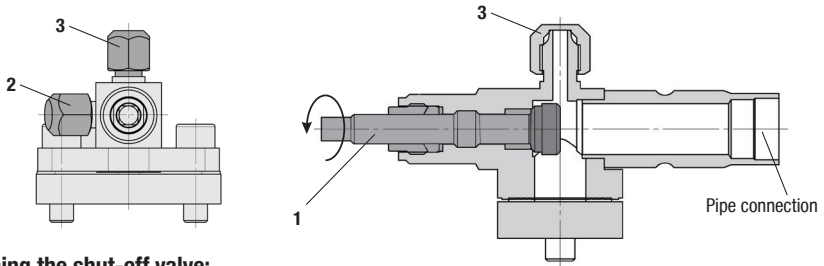

Fig. 10

# 4| Compressor assembly

## 4.9 Operating mode of the lockable service connections



### Opening the shut-off valve:

- a) Spindle 1: turn to the left (counter-clockwise) as far as it will go.  
—> Shut-off valve fully opened / service connection 2 closed

Fig. 11

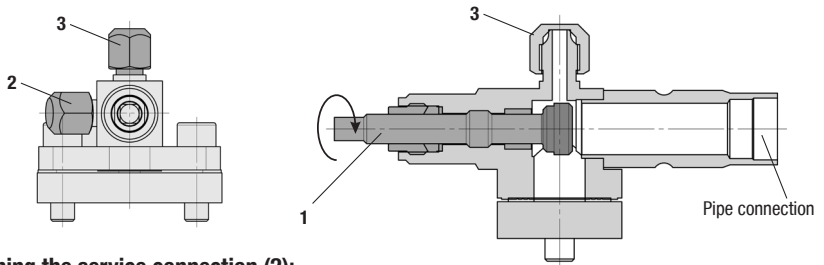

### Opening the service connection (2):

- b) Spindle 1: Turn  $\frac{1}{2}$  - 1 rotation to the right.  
—> Service connection 2 opened / shut-off valve opened.  
Connection 3 is provided for safety devices and is not lockable.

Fig. 12

After activating the spindle, generally fit the spindle protection cap again and tighten with 14-16 Nm. This serves as a second sealing feature during operation.

## 4.10 Suction pipe filter

For systems with long pipes and higher degree of contamination, a filter on the suction-side is recommended. The filter has to be renewed depending on the degree of contamination (reduced pressure loss).

GB

# 5| Commissioning

## 5.1 Preparations for start-up



### INFO!

**To protect the compressor against inadmissible operating conditions, high-pressure and low-pressure pressostats are mandatory on the installation side.**

The compressor has undergone trials in the factory and all functions have been tested. There are therefore no special running-in instructions.

**Check the compressor for transport damage!**

## 5.2 Pressure strength test

The compressor has been tested in the factory for pressure integrity. If however the entire system is to be subjected to a pressure integrity test, this should be carried out in accordance with EN 378-2 or a corresponding safety standard without the inclusion of the compressor.

## 5.3 Leak test



### DANGER!

#### Risk of bursting!

**The compressor must only be pressurised using dried nitrogen (N<sub>2</sub>). Never pressurise with oxygen or other gases!**

**The maximum permissible overpressure of the compressor must not be exceeded at any time during the testing process (see name plate data)! Do not mix any refrigerant with the nitrogen as this could cause the ignition limit to shift into the critical range.**

GB

- Carry out the leak test on the refrigerating plant in accordance with EN 378-2 or a corresponding safety standard, while always observing the maximum permissible overpressure for the compressor.

## 5.4 Evacuation

- First evacuate the **system** and then include **the compressor in the evacuation process**.
- Relieve the compressor pressure.
- Open the suction and discharge line valves.
- Evacuate the suction and discharge pressure sides using the vacuum pump.
- At the end of the evacuation process, the vacuum should be < 1.5 mbar when the pump is switched off.
- Repeat the process as often as is required.

# 5 | Commissioning

## 5.5 Refrigerant charge



**CAUTION!** Wear personal protective clothing such as goggles and protective gloves!



**ATTENTION!**

- Avoid overfilling the system with refrigerant!
- To avoid shifts in concentration, zeotropic refrigerant blends (e.g. R407C) must always be added to the refrigerating plant in liquid form.
- Do not pour liquid refrigerant through the suction line valve on the compressor.
- It is not permissible to mix additives with the oil and refrigerant.

- Make sure that the suction and discharge line valves are open.
- With the compressor switched off, add the liquid refrigerant directly to the condenser or receiver, breaking the vacuum.
- If the refrigerant needs topping up after starting the compressor, it can be topped up in vapour form on the suction side, or, taking suitable precautions, also in liquid form at the inlet to the evaporator.

GB

## 5.6 Shaft seal



**ATTENTION!** Failure to observe the following instructions can cause loss of refrigerant and damage to the shaft seal!



**INFO!** The shaft seal seals and lubricates with oil. An oil leakage of 0.05 ml per operating hour is therefore normal. This applies particularly during the run-in phase (200–300 h).

The compressor shaft is sealed to outside using a shaft seal. The sealing element rotates with the shaft.

The following is especially important to ensuring fault-free operation:

- The complete refrigerant circuit must be correctly executed and clean inside.
- Heavy shocks and vibrations to the shaft as well as continuous cyclic operation are to be avoided.
- The sealing surfaces can stick together during prolonged downtimes (e.g. winter). Therefore, run the system every 4 weeks for 10 minutes.

# 5| Commissioning

## 5.6.1 Notes on replacing the shaft seal

Since changing the shaft seal involves encroaching into the refrigerant circuit, this is only recommended, if the seal is losing refrigerant, or if oil is escaping in excess of the permissible amount (see information on page 14, chapter 5.6, "Shaft seal"). Changing the shaft seal is described in the relevant spare part kit.

The shaft seal is a wearing part, and its service life depends on the prevailing conditions. Damaging effects on the shaft seal:

- Too little suction gas superheat, particularly during wet operation
- Too high or too low belt tension
- Thermal overload (operation outside the limits of application)
- Frequent cycling
- Long periods of stoppage
- Material deposits / dirt from the system

Due to these effects, the shaft seal can develop leaks, and it must then be replaced.

## 5.7 Avoiding liquid shocks



**ATTENTION! Slugging can damage the compressor and cause refrigerant to leak.**

GB

### To prevent liquid shocks:

- The complete refrigeration plant must be correctly designed and executed.
- The capacities of all components must be compatible (particularly evaporator and expansion valve).
- Suction gas superheating at the evaporator output should be at least 7–10 K (check setting of the expansion valve).
- The system must reach a state of equilibrium.
- Particularly in critical systems (e.g. several evaporator points), suitable measures, e.g. use of liquid traps, solenoid valve in the liquid line, etc. are recommended.

# 6 | Maintenance

## 6.1 Preparation



**WARNING!** Before starting any work on the compressor:

- Switch off the compressor and secure it to prevent a restart.
- Relieve compressor of system pressure.
- Prevent air from infiltrating the system!

After maintenance has been performed:

- Connect safety switch.
- Evacuate compressor.
- Release switch lock.

## 6.2 Work to be carried out

**Oil change:** In principle, an oil change is not a mandatory requirement, if the equipment is correctly manufactured and properly operated. Based on decades of experience, we recommend however that the following oil change/service work is carried out:

- Initial oil change during the first maintenance of the vehicle (at the latest after one year)
- Then after every 5,000 operating hours, at the latest however after 3 years. Also clean the oil filter.
- An oil change is also necessary, if the oil is very cloudy and dark, or after repairs have been carried out on the compressor.

GB

**Emptying the shaft seal oil reservoir:** As required depending on use, but at the latest after 1 year or approx. 1,400 operating hours

**Where requirements are higher during use** (frequent operation at the limits of application, or in hotlands with over +40 °C ambient temperature, or in the case of deep freezing), the following requirements must be observed:

- Initial oil change during the first maintenance of the vehicle (at the latest after one year)
- Then an oil change after every 2,000 operating hours, at the latest however after two years. Also clean the oil filter.

### Preventive maintenance

The above requirements for higher use applications also apply in the case of preventive maintenance. The shaft seal must also be changed after 3 years.

**Regular inspections (at least annually):** Checks to be carried out on oil level in the oil sight glass, oil fill level of the shaft seal in the oil drain hose, absence of leaks in the compressor, running noise, vibrations, pressures, temperatures, and functioning of auxiliary devices such as the capacity control.

## 6| Maintenance

### 6.3 Recommended spare parts/accessories

Maintenance set for oil change

- **BOCK**lub E55 1 l
- Oil drain screw with seal

Maintenance set for shaft seal

- shaft seal kit
- **BOCK**lub E55 1 l
- Oil drain screw with seal

Available spare parts and accessories can be found on our compressor selection tool under [vap.bock.de](http://vap.bock.de) as well as in our online spare parts catalogue at [bockshop.bock.de](http://bockshop.bock.de).

**Only use original Bock spare parts!**

### 6.4 Lubricants / Oils

The oil type filled as standard in the factory is marked on the name plate, and this should always be used, even in the case of maintenance units. Alternative oil types can vary significantly in quality due to additives or inferior raw materials by the manufacturer. Validation within the compressors entire operating limits can not be guaranteed, if such alternative oil types are used. It is for this reason, that we only recommend the use of oil from Bock! Bock assumes no liability for any damage arising from alternative oil types.

**GB**

Refrigerants	Bock standard oil types
<b>HFC</b> (e.g. R134a, R407, R 404A)	<b>BOCK</b> lub E55
<b>HCFC</b> (e.g. R22)	<b>BOCK</b> lub A46

### 6.5 Decommissioning

Close the shut-off valve on the compressor. Drain the refrigerant (it must not be discharged directly into the environment) and dispose of it according to the regulations. When the compressor is depressurised, undo the fastening screws of the shut-off valves. Remove the compressor using an appropriate hoist. Dispose of the oil inside in accordance with the valid national regulations.

## 6| Maintenance

### 6.6 Valve plate, TK version

Based on the tried-and-tested N valve plate system, a valve plate with reduced dead space has been adapted to the FK20 TK specifically for applications in the deep-freeze area. The system is equipped with a non-interchange safeguard to avoid confusing it with N valve plate.

#### Non-interchange safeguard for the FK20 valve plate, TK version:

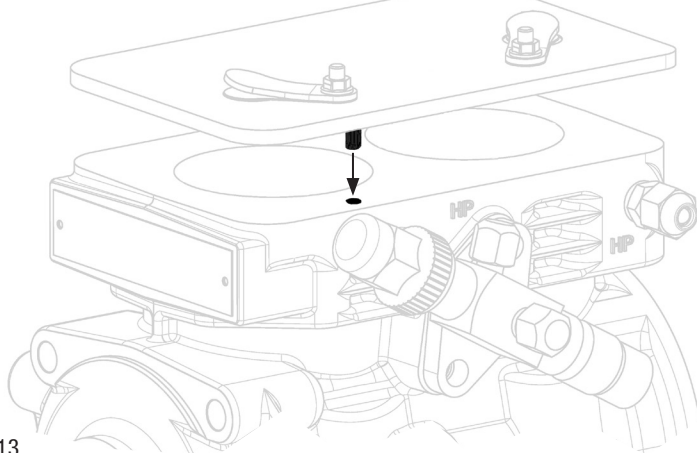

Fig. 13

GB

## 7| Accessories

### 7.1 Thermal protection thermostat (Item No. 097B07595\*)

A special intermediate flange, located below the discharge line valve, is used to attach the sensor element (Part no. 097B04175\*). Wire the thermal protection thermostat in series with the control line.

Technical Data:

Switching voltage max. :	24 V DC
Switching current max. :	2.5 A at 24 V DC
Switch-off temperature :	145 °C ± 5 K
Switch-on temperature :	approx. 115 °C

\* Please note that the legacy BOCK code numbers are without 097B

## 8| Technical data

Type	No. of cylinders	Displacement cm <sup>3</sup>	Swept volume (1450 rpm) m <sup>3</sup> /h	Weight kg	Connections		Oil charge Ltr.	Inertia moment of the driving unit [kgm <sup>2</sup> ]	Lubrication	Oil pump
					Discharge line DV mm / inch	Suction line SV mm / inch				
FK20/120	2	118	10,3	15,0	16 / 5/8	16 / 5/8	0,7	0,0013	Forced lubrication	Independent of rotational direction
FK20/145		143	12,4	14,0						
FK20/170		170	14,8	14,0						

The technical data for the different designs K, N and TK are identical.  
The compressor type data therefore do not mention these additions.



## 9| Dimensions and connections

<b>SV</b>	Suction line	see technical data, Chapter 8	
<b>DV</b>	Discharge line		
<b>A</b>	Connection suction side, not lockable		$7/16"$ UNF
<b>A1</b>	Connection suction side, lockable		$7/16"$ UNF
<b>A2</b>	Connection suction side, not lockable		$1/8"$ NPTF
<b>B</b>	Connection discharge side, not lockable		$7/16"$ UNF
<b>B1</b>	Connection discharge side, lockable		$7/16"$ UNF
<b>F</b>	Oil drain plug		G $1/8"$
<b>G</b>	Opt. connection for oil sump heating		G $3/8"$ <sup>1)</sup>
<b>H</b>	Oil charge plug		$1/4"$ NPTF
<b>K</b>	Sight glass		1 $1/8"$ - 18 UNEF

<sup>1)</sup> = Only possible ex factory

# 10 | Declaration of incorporation

## Declaration of incorporation for incomplete machinery in accordance with EC Machinery Directive 2006/42/EC, Annex II 1. B

Manufacturer: Bock GmbH  
Benzstraße 7  
72636 Frickenhausen, Germany

We, as manufacturer, declare in sole responsibility that the incomplete machinery

Name: Semi-hermetic compressor  
Types: HG(X)12P/60-4 S (HC) ..... HG(X)88e/3235-4(S) (HC)  
UL-HGX12P/60 S 0,7 ..... UL-HGX66e/2070 S 60  
HGX12P/60 S 0,7 LG ..... HGX88e/3235 (ML/S) 95 LG  
HG(X)22(P)(e)/125-4 A ..... HG(X)34(P)(e)/380-4 (S) A  
HGX34(P)(e)/255-2 (A) ..... HGX34(P)(e)/380-2 (A)(K)  
HA(X)12P/60-4 ..... HA(X)6/1410-4  
HAX22e/125 LT 2 LG ..... HAX44e/665 LT 14 LG  
HGX12e/20-4 (ML/S) CO<sub>2</sub> (LT) ..... HGX44e/565-4 S CO<sub>2</sub>  
UL-HGX12e/20 (S/ML) 0,7 CO<sub>2</sub> (LT) ... UL-HGX44e/565 S 31 CO<sub>2</sub>  
HGX12/20-4 (ML/S/SH) CO<sub>2</sub>T ..... HGX46/440-4 (ML/S/SH) CO<sub>2</sub> T  
UL-HGX12/20 ML(P) 2 CO<sub>2</sub>T ..... UL-HGX46/440 ML(P) 53 CO<sub>2</sub>T  
HGZ(X)7/1620-4 ..... HGZ(X)7/2110-4  
HGZ(X)66e/1340 LT 22 ..... HGZ(X)66e/2070 LT 35  
HRX40-2 CO<sub>2</sub> T H ..... HRX60-2 CO<sub>2</sub> T H

Name: Open type compressor  
Types: F(X)2 ..... F(X)88/3235 (NH3)  
FK(X)1 ..... FK(X)3  
FK(X)20/120 (K/N/TK) ..... FK(X)50/980 (K/N/TK)

Serial number: BC0000A001 – BN99999Z999

complies with the following provisions of the above-mentioned Directive:

According to Annex I, points 1.1.2, 1.1.3, 1.1.5, 1.3.2, 1.3.3, 1.3.7, 1.5.1, 1.5.2, 1.5.13 and 1.7.1 to 1.7.4 (excepted 1.7.4 f) are fulfilled.

Applied harmonised standards, in particular:

EN ISO 12100 :2010 Safety of machinery — General principles for design — Risk assessment and risk reduction  
EN 12693 :2008 Refrigerating systems and heat pumps — Safety and environmental requirements — Positive displacement refrigerant compressors

Remarks: We also declare that the special technical documentation for this incomplete machine has been created in accordance with Annex VII, Part B and we obligate to provide these upon reasoned request from the individual national authorities by data transfer.

Commissioning is prohibited until it has been confirmed that the machinery into which the incomplete machine above is to be incorporated complies with the EC Machinery Directive and an EC Declaration of Conformity, Annex II. 1. A exists.

Authorized person for compiling and handing over technical documentation:

Bock GmbH  
Alexander Layh  
Benzstraße 7  
72636 Frickenhausen, Germany

Frickenhausen, 04th of January 2021



i. A. Alexander Layh, Global Head of R&D

# 10 | Declaration of incorporation

## Declaration of incorporation of partly completed machinery in accordance with UK Statutory Instrument Supply of Machinery (Safety) Regulations 2008, Annex II 1. B

Manufacturer: Bock GmbH  
Benzstraße 7  
72636 Frickenhausen, Germany



We, as manufacturer, declare in sole responsibility that the partly completed machinery

Name: Semi-hermetic compressor  
Types: HG(X)12P/60-4 S (HC) ..... HG(X)88e/3235-4(S) (HC)  
UL-HGX12P/60 S 0,7 ..... UL-HGX66e/2070 S 60  
HGX12P/60 S 0,7 LG ..... HGX88e/3235 (ML/S) 95 LG  
HG(X)22(P)(e)/125-4 A ..... HG(X)34(P)(e)/380-4 (S) A  
HGX34(P)(e)/255-2 (A) ..... HGX34(P)(e)/380-2 (A)(K)  
HA(X)22e/125-4 ..... HA(X)6/1410-4  
HAX22e/125 LT 2 LG ..... HAX44e/665 LT 14 LG  
HGX12e/20-4 (ML/S) CO<sub>2</sub> (LT) ..... HGX44e/565-4 S CO<sub>2</sub>  
UL-HGX12e/20 (S/ML) 0,7 CO<sub>2</sub> (LT)... UL-HGX44e/565 S 31 CO<sub>2</sub>  
HGX12/20-4 (ML/S/SH) CO<sub>2</sub>T ..... HGX46/440-4 (ML/S/SH) CO<sub>2</sub> T  
UL-HGX12/20 ML(P) 2 CO<sub>2</sub>T ..... UL-HGX46/440 ML(P) 53 CO<sub>2</sub>T  
HGZ(X)7/1620-4 ..... HGZ(X)7/2110-4  
HGZ(X)66e/1340 LT 22 ..... HGZ(X)66e/2070 LT 35  
HRX40-2 CO<sub>2</sub> T H ..... HR(Z)X60-2 CO<sub>2</sub> T (H)(V)

Name: Open type compressor  
Types: F(X)2 ..... F(X)88/3235 (NH3)  
FK(X)1 ..... FK(X)3  
FK(X)20/120 (K/N/TK) ..... FK(X)50/980 (K/N/TK)

Serial number: BC0000A001 – BN99999Z999

GB

complies with the following provisions of the above-mentioned Statutory instrument:

According to Schedule 2, part1, points 1.1.2, 1.1.3, 1.1.5, 1.3.2, 1.3.3, 1.3.7, 1.5.1, 1.5.2, 1.5.13 and 1.7.1 to 1.7.4 (excepted 1.7.4 f) are fulfilled.

Designated standards: EN ISO 12100 :2010 Safety of machinery — General principles for design — Risk assessment and risk reduction  
EN 12693 :2008 Refrigerating systems and heat pumps — Safety and environmental requirements — Positive displacement refrigerant compressors

Remarks: We also declare that the special technical documentation for this partly completed machine has been created in accordance with Annex II, 1. B and we obligate to provide these upon reasoned request from the individual national authorities by data transfer.

Commissioning is prohibited until it has been confirmed that the machinery into which the partly completed machine above is to be incorporated complies with the UK Statutory Instrument Supply machinery (Safety) regulations 2008 and an EC Declaration of Conformity, Annex II, 1. A exists.

Authorized person for compiling and handing over technical documentation:

Bock GmbH  
Alexander Layh  
Benzstraße 7  
72636 Frickenhausen, Germany

Frickenhausen, 14th of October 2022

i. A. Alexander Layh, Global Head of R&D



**Danfoss A/S**  
Climate Solutions • danfoss.com • +45 7488 2222

Any information, including, but not limited to information on selection of product, its application or use, product design, weight, dimensions, capacity or any other technical data in product manuals, catalogues descriptions, advertisements, etc. and whether made available in writing, orally, electronically, online or via download, shall be considered informative, and is only binding if and to the extent, explicit reference is made in a quotation or order confirmation. Danfoss cannot accept any responsibility for possible errors in catalogues, brochures, videos and other material. Danfoss reserves the right to alter its products without notice. This also applies to products ordered but not delivered provided that such alterations can be made without changes to form, fit or function of the product.

All trademarks in this material are property of Danfoss A/S or Danfoss group companies. Danfoss and the Danfoss logo are trademarks of Danfoss A/S. All rights reserved.