

BOCK® HGX22(P)(e) A

Operating guide

HGX22e/125-4 A	HGX22e/125-4 S A
HGX22e/160-4 A	HGX22e/160-4 S A
HGX22e/190-4 A	HGX22e/190-4 S A
HGX22P/125-4 A	HGX22P/125-4 S A
HGX22P/160-4 A	HGX22P/160-4 S A
HGX22P/190-4 A	HGX22P/190-4 S A

About these instructions

Read these instructions before assembly and before using the compressor. This will avoid misunderstandings and prevent damage. Improper assembly and use of the compressor can result in serious or fatal injury.

Observe the safety instructions contained in these instructions.

These instructions must be passed onto the end customer along with the unit in which the compressor is installed.

1	Safety	4
1.1	Identification of safety instructions	
1.2	Qualifications required of personnel	
1.3	General safety instructions	
1.4	Intended use	
2	Product description	6
2.1	Short description	
2.2	Name plate	
2.3	Type key	
3	Areas of application	8
3.1	Refrigerants	
3.2	Oil charge	
3.3	Limits of application	
4	Compressor assembly	10
4.1	Storage and transport	
4.2	Setting up	
4.3	Maximum permissible inclination	
4.4	Pipe connections	
4.5	Pipes	
4.6	Laying suction and discharge lines	
4.7	Operating the shut-off valves	
4.8	Operating mode of the lockable service connections	
4.9	Suction pipe filter and filter drier	
5	Electrical connection	14
5.1	Information for contactor and motor contactor selection	
5.2	Connection of the driving motor	
5.3	Circuit diagram	
5.4	Electronic trigger unit INT69 G	
5.5	Connection of the trigger unit INT69 G	
5.6	External connection INT69 G	
5.7	Function test of the trigger unit INT69 G	
5.8	Selection and operation of compressors with frequency converters	
6	Commissioning	21
6.1	Preparations for start-up	
6.2	Pressure strength test	
6.3	Leak test	
6.4	Evacuation	
6.5	Refrigerant charge	
6.6	Start-up	
6.7	Avoiding slugging	
7	Maintenance	23
7.1	Preparation	
7.2	Work to be carried out	
7.3	Spare parts recommendation/accessories	
7.4	Lubricants / oil	
7.5	Decommissioning	
8	Technical data	24
9	Dimensions and connections	25
10	Declaration of incorporation	26

1| Safety

1.1 Identification of safety instructions:



DANGER Indicates a dangerous situation which, if not avoided, will cause immediate fatal or serious injury.



WARNING Indicates a dangerous situation which, if not avoided, may cause fatal or serious injury.



CAUTION Indicates a dangerous situation which, if not avoided, may cause fairly severe or minor injury.



ATTENTION Indicates a situation which, if not avoided, may cause property damage.



INFO Important information or tips on simplifying work.

GB

1.2 Qualifications required of personnel



WARNING Inadequately qualified personnel poses the risk of accidents, the consequence being serious or fatal injury. Work on compressors is therefore reserved for personnel which is qualified to work on pressurized refrigerant systems:

- For example, a refrigeration technician, refrigeration mechatronic engineer. As well as professions with comparable training, which enables personnel to assemble, install, maintain and repair refrigeration and air-conditioning systems. Personnel must be capable of assessing the work to be carried out and recognising any potential dangers.

1 | Safety

1.3 General safety instructions



WARNING

Risk of accidents.

Refrigerating compressors are pressurised machines and as such call for heightened caution and care in handling.

The maximum permissible overpressure must not be exceeded, even for testing purposes.

Risk of burns!

- Depending on the operating conditions, surface temperatures of over 60°C on the discharge side or below 0°C on the suction side can be reached.

- Avoid contact with refrigerant necessarily.

Contact with refrigerant can cause severe burns and skin damage.

1.4 Intended use



WARNING

The compressor may not be used in potentially explosive environments!

GB

These assembly instructions describe the standard version of the compressor named in the title manufactured by Bock. Bock refrigerating compressors are intended for installation in a machine (within the EU according to the EU Directives 2006/42/EC Machinery Directive and 2014/68/EU Pressure Equipment Directive).

Commissioning is permissible only if the compressor has been installed in accordance with these assembly instructions and the entire system into which it is integrated has been inspected and approved in accordance with legal regulations.

The compressors are intended for use in refrigeration systems in compliance with the limits of application.

Only the refrigerant specified in these instructions may be used.

Any other use of the compressor is prohibited!

2 | Product description

2.1 Short description

- Semi-hermetic two-cylinder reciprocating compressor with oil pump lubrication.
- Lightweight aluminum design
- Suction gas cooled drive motor

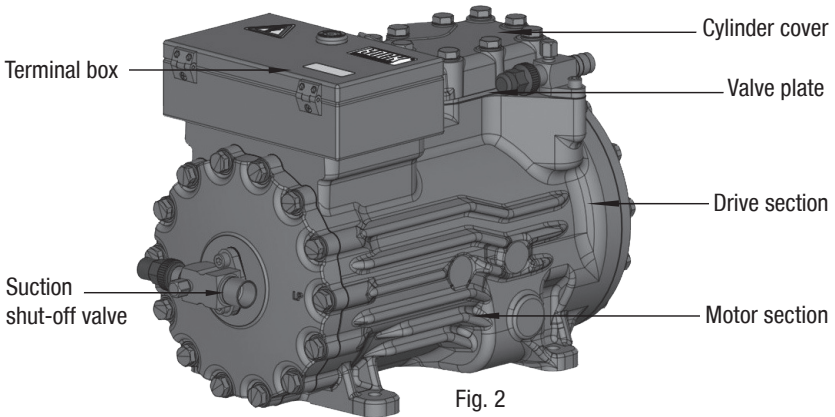
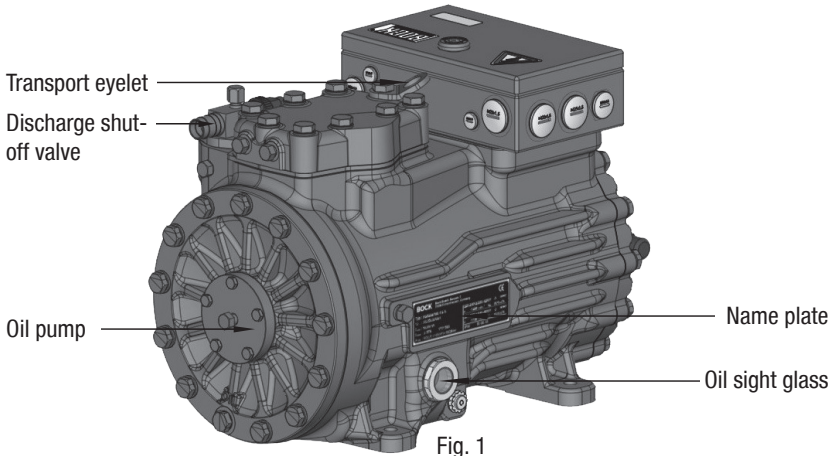

Dimension and connection values can be found in Chapter 9

2| Product description

2.2 Name plate (example)

BOCK Bock GmbH, Benzstr. 7 72636 Frickenhausen, Germany		CE
1 Typ : HGX22e/190-4 S A	220-240VΔ/380-420VY -3- 50HZ	6
2 Nr. : AS35830A001	n : 1450 min ⁻¹ V _{th.} : 16,5 m ³ /h	7
3 I _{max} : 16,2/9,4A	265-290VΔ/440-480VY -3- 60HZ	8
4 I _{block} Δ: 87A Y: 50A	n : 1740 min ⁻¹ V _{th.} : 19,8 m ³ /h	9
5 P _{max} : ND(LP) / HD(HP)=19/28 bar	IP66 Öl: BOCK lub E55	10
		11
		12
		13

Fig. 3

1 Type designation	6 Voltage, circuit, frequency	} 50 Hz
2 Machine number	7 Nominal rotation speed	
3 maximum operating current	8 Displacement	} 60 Hz
4 Starting current (rotor blocked)	9 Voltage, circuit, frequency	
5 ND (LP): max. admissible operating pressure (g) Low pressure side	10 Nominal rotation speed	
HD (HP): max. admissible operating pressure (g) High pressure side	11 Displacement	
	12 Oil type filled at the factory	
	13 Terminal box protection type	

i Observe the limits of application diagrams!

i Electrical accessories can change the IP protection class!

GB

2.3 Type key (example)

HG X 22 e / 190-4 S A

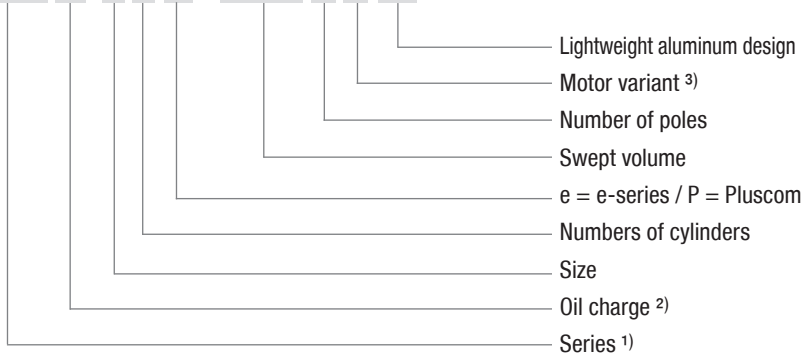

1) HG - Hermetic Gas-cooled (suction gas-cooled)

2) X - Ester oil charge (HFC refrigerant, e.g. R134a, R404A/R507, R407C)

3) S - More powerful motor, e.g. for air-conditioning applications

3| Areas of application

3.1 Refrigerants

- HFKW / HFC: R134a, R404A/R507, R407C, R513A

3.2 Oil charge

- The compressors are filled at the factory with the following oil type:
 - for R134a, R404A/R507, R407C, R513A **BOCK** lub E55

Compressors with ester oil charge (**BOCK** lub E55) are marked with an X in the type designation (e.g. HGX22e/190-4 A).



INFO!

For refilling, we recommend the above oil types.
Alternatives: see chapter 7.4



ATTENTION!

The oil level must be in the visible part of the sight glass; damage to the compressor is possible if overfilled or underfilled!

max.

oil level

min.

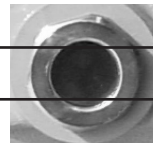

≈ 0,8 Ltr.

Fig. 4

GB

3.3 Limits of application



ATTENTION! • Compressor operation is possible within the operating limits. These can be found in Bock compressor selection tool (VAP) under vap.bock.de. Observe the information given there.

- Permissible ambient temperature (-20°C) - (+60°C)
- Max. permissible discharge end temperature 140°C.
- Max. permissible switching frequency 8x /h.
- A minimum running time of 3 min. steady-state condition (continuous operation) must be achieved.
- For operation with supplementary cooling:
 - Use only oils with high thermal stability.
 - Avoid continuous operation near the limits.
- For operation with frequency converter (see also chapter 5.8):
 - The potential control range of the compressor is 30-70 Hz.
 - Max. permissible current consumption must not be exceeded.
- At max. rotation speed therefore, the application limit can be reduced.
 - Use a thermal protection thermostat.
 - Do not operate an additional capacity controller.
 - Oil return at low frequency must be guaranteed.



ATTENTION! • When operating in the vacuum range, there is a danger of air entering on the suction side. This can cause chemical reactions, a pressure rise in the condenser and an elevated compressed-gas temperature. Prevent the ingress of air at all costs!

**Max. permissible operating pressure (LP/HP)¹⁾:
19/28 bar**

¹⁾ LP = Low pressure
HP = High pressure

4 | Compressor assembly



INFO

New compressors are factory-filled with inert gas. Leave this service charge in the compressor for as long as possible and prevent the ingress of air. Check the compressor for transport damage before starting any work.

4.1 Storage and transport



Fig. 5



Fig. 6

- Storage at (-30°C) - (+70°C), maximum permissible relative humidity 10% - 95%, no condensation
- Do not store in a corrosive, dusty, vaporous atmosphere or in a combustible environment.
- Use transport eyelet.
- Do not lift manually!
- Use lifting gear!

4.2 Setting up



ATTENTION! Attachments (e.g. pipe holders, additional units, fastening parts, etc.) directly to the compressor are not permissible!

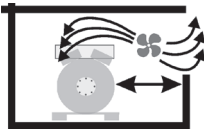

Fig. 7

- Provide adequate clearance for maintenance work.
- Ensure adequate compressor ventilation.



Fig. 8

- Do not use in a dusty, damp atmosphere or a combustible environment.

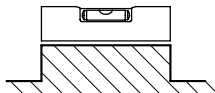

Fig. 9

- Set up on an even surface or frame with sufficient load-bearing capacity.

GB

4 | Compressor assembly

4.3 Maximum permissible inclination



ATTENTION! Poor lubrication can damage the compressor. Respect the stated values.

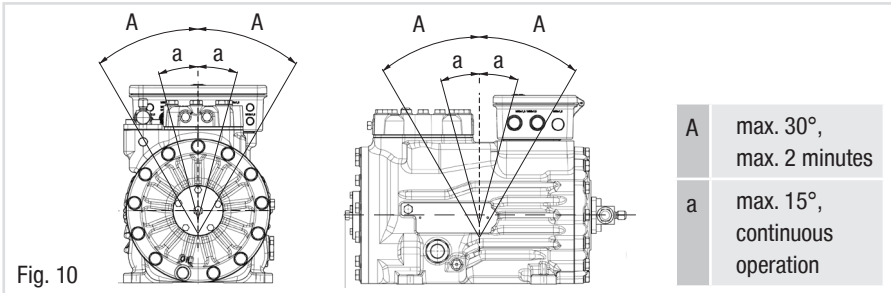

Fig. 10

4.4 Pipe connections

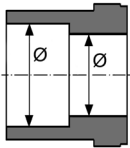

Fig. 11: Stepped internal diameters

- The **discharge and suction line valves** have stepped internal diameters so that pipes with standard millimetre and inch dimensions can be used. The depth of pipe insertion will depend on the dimension.
- The connection diameters of the shut-off valves are rated for maximum compressor output. **The required pipe cross-section must be matched to the output. The same applies for non-return valves.**

GB



ATTENTION! Overheating can damage the valve. Remove the pipe supports from the valve for soldering. Solder them with protective gas to prevent oxidation products (scale).

4 | Compressor assembly

4.5 Pipes

Pipes and system components must be clean and dry inside and free of scale, swarf and layers of rust and phosphate. Only use air-tight parts.

- Lay pipes correctly. Suitable vibration compensators must be provided to prevent pipes being cracked and broken by severe vibrations.
- Ensure a proper oil return.
- Keep pressure losses to an absolute minimum.

6.5 Laying suction and discharge lines



ATTENTION Improperly installed pipes can cause cracks and tears, the result being a loss of refrigerant.



INFO Proper layout of the suction and discharge lines directly after the compressor is integral to the system's smooth running and vibration behaviour.

A rule of thumb: Always lay the first pipe section starting from the shut-off valve **downwards and parallel to the drive shaft**.

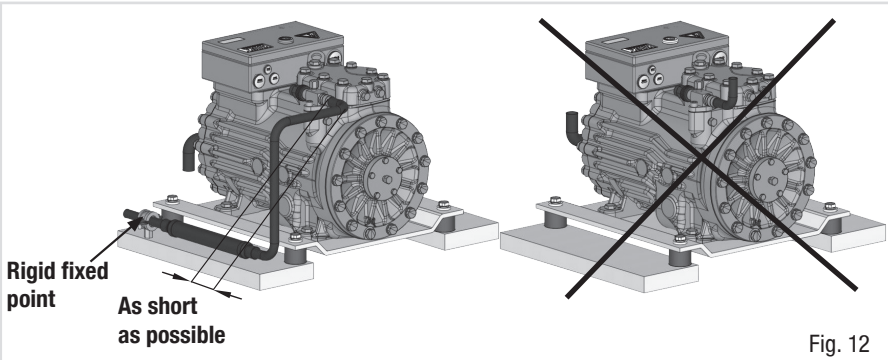

Fig. 12

4.7 Operating the shut-off valves

- Before opening or closing the shut-off valve, release the adjustable valve spindle seal by approx. 1/4 of a turn counter-clockwise.
- After activating the shut-off valve, re-tighten the adjustable valve spindle seal clockwise.

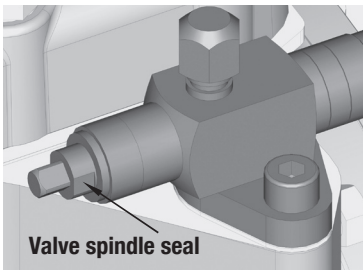

Fig. 13

Fig. similar

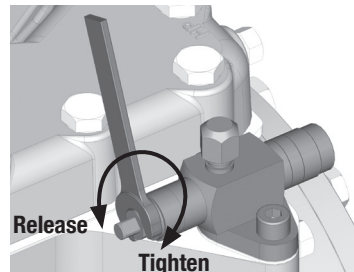

Fig. 14

Fig. similar

4 | Compressor assembly

4.8 Operating mode of the lockable service connections

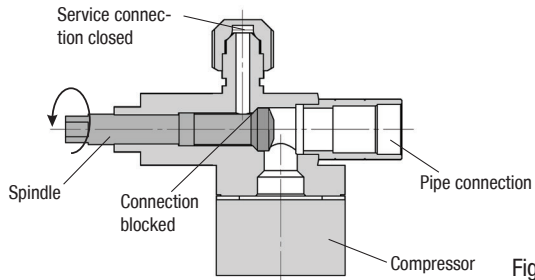

Fig. 15

Opening the shut-off valve:

Spindle: turn to the left (counter-clockwise) as far as it will go.

—> Shut-off valve completely opened / service connection closed.

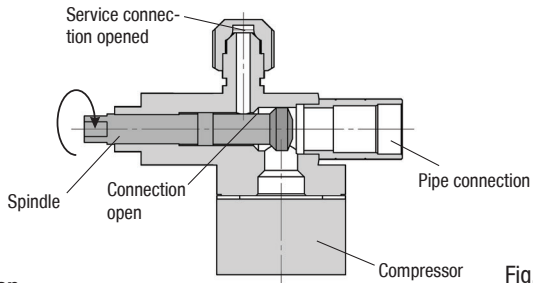

Fig. 16

Opening the service connection

Spindle: Turn $\frac{1}{2}$ - 1 turn to the right clockwise.

—> Service connection opened / shut-off valve opened.

After activating the spindle, generally fit the spindle protection cap again and tighten with 14-16 Nm. This serves as a second sealing feature during operation.

4.9 Suction pipe filter and filter drier

For systems with long pipes and higher degree of contamination, a filter on the suction-side is recommended. The filter has to be renewed depending on the degree of contamination (reduced pressure loss).

Moisture in the refrigeration circuit can lead to crystal and hydrate formation. For this reason, we recommend using a filter drier and a sight glass with a moisture indicator.

5| Electrical connection

5 Electrical connection



DANGER! High voltage! Risk of electric shock! Only carry out work when the electrical system is disconnected from the power supply!



ATTENTION! When attaching accessories with an electrical cable, a minimum bending radius of 3 x the cable diameter must be maintained for laying the cable.



INFO!

- Connect the compressor motor in accordance with the circuit diagram (see inside of terminal box).
- Use suitable cable entry point of the correct protection type (see name plate) for routing cables into the terminal box. Insert the strain reliefs and prevent chafe marks on the cables.
- Compare the voltage and frequency values with the data for the mains power supply. **Only connect the motor if these values are the same.**

5.1 Information for contactor and motor contactor selection

All protection devices and switching or monitoring units must be fitted in accordance with the local safety regulations and established specifications (e.g. VDE) as well as with the manufacturer's information. **Motor protection switches are required!** Motor contactors, feed lines, fuses and motor protection switches must be rated on the basis of the maximum working current (see name plate). For motor protection use a current-dependent and time-delayed overload protection device for monitoring all three phases. Set the overload protection device so that it must be actuated within 2 hours, if there is 1.2 times the max. working current.

GB

5| Electrical connection

5.2 Connection of the driving motor

The compressor is designed with a motor for star-delta circuits.

Designation on the name plate
Δ / Y

Star-delta start-up is only possible in the Δ voltage range. Example:

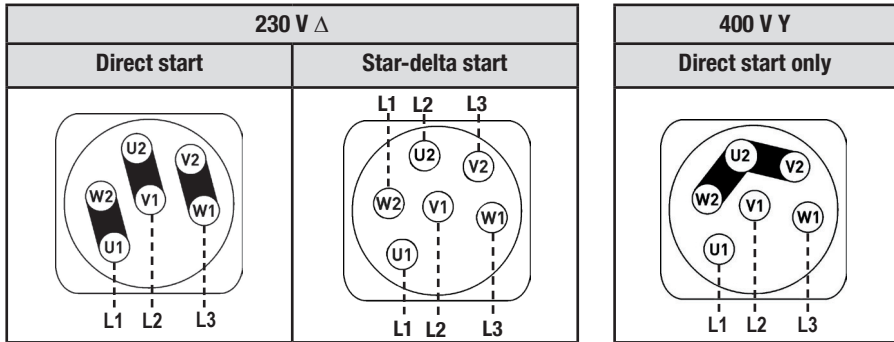

INFO!

The connection examples shown refer to the standard version. In the case of special voltages, the instructions affixed to the terminal box apply.

GB

5.3 Circuit diagram for direct start 230 V Δ / 400 V Y

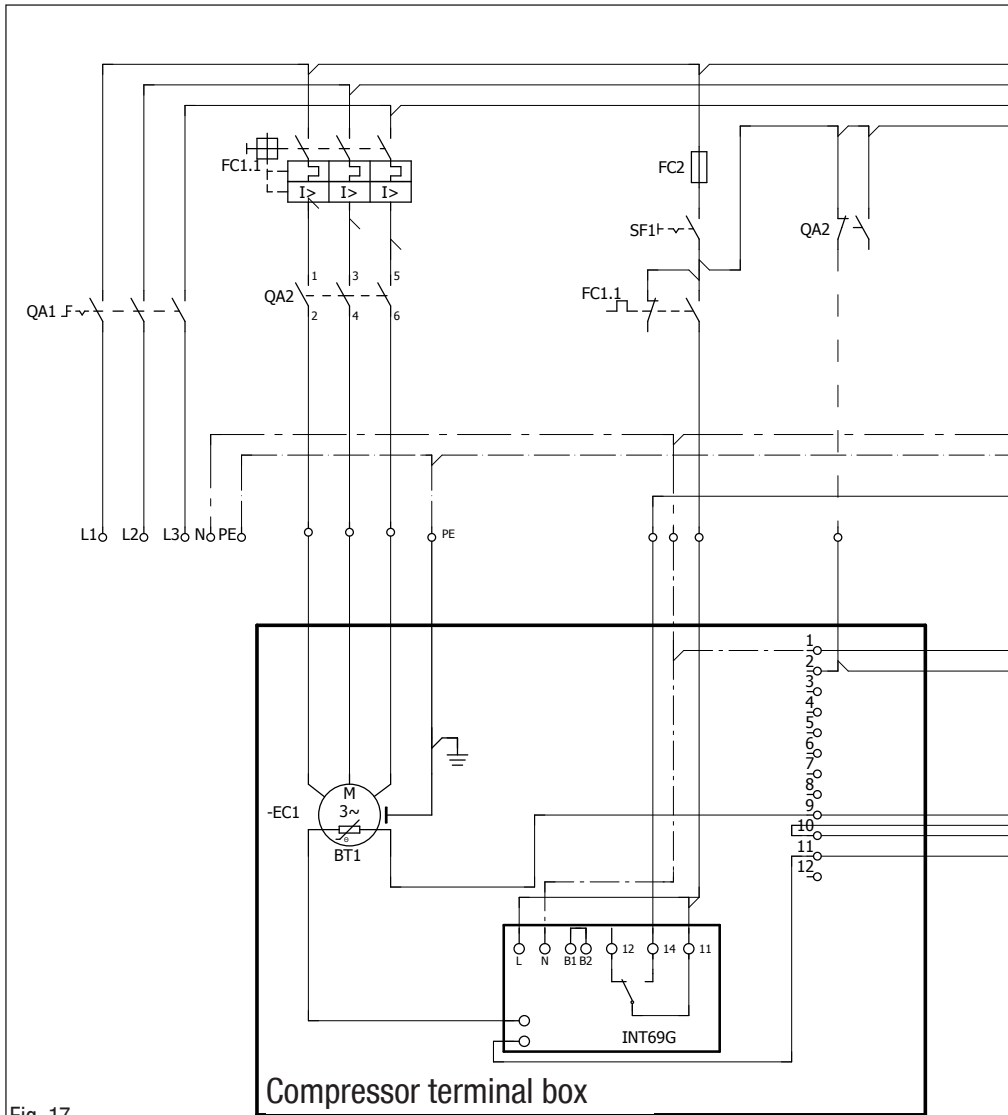
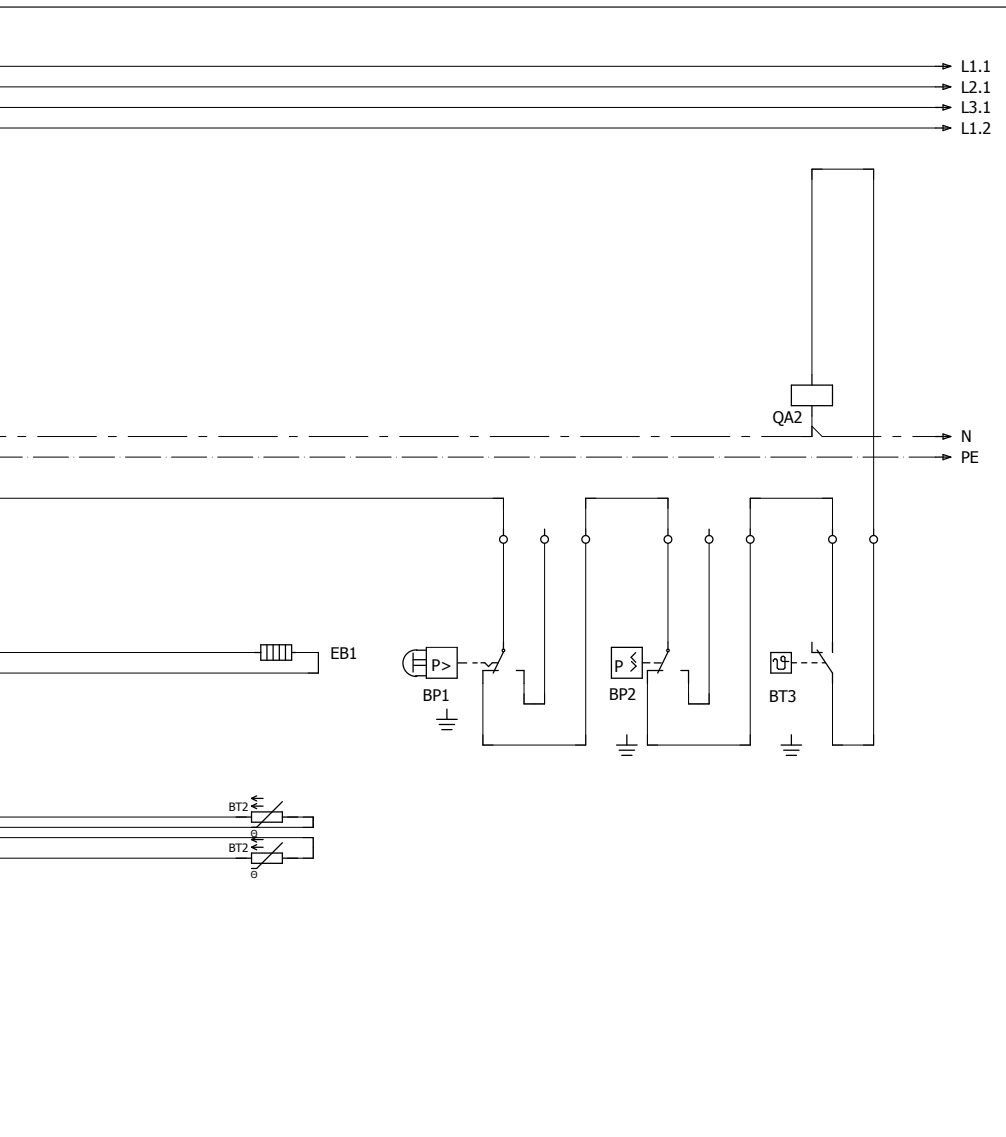

Fig. 17

BT1	Cold conductor (PTC sensor) motor winding
BT2	Thermal protection thermostat (PTC sensor)
FC1	Load circuit safety switches
FC2	Control power circuit fuse
BP1	High pressure safety monitor
BP2	Safety chain (high/low pressure monitoring)
BT3	Release switch (thermostat)



GB

QA1	Main switch
SF1	Control voltage switch
EC1	Compressor motor
QA2	Compressor contactor
INT69 G	Electronic trigger unit INT69 G
EB1	Oil sump heater

5| Electrical connection

5.4 Electronic trigger unit INT69 G

The compressor motor is fitted with cold conductor temperature sensors (PTC) connected to the electronic trigger unit INT69 G in the terminal box. In case of excess temperature in the motor winding, the INT69 G deactivates the motor contactor. Once cooled, it can be restarted only if the electronic lock of the output relay (terminals B1+B2) is released by interrupting the supply voltage.

The hot gas side of the compressor can also be protected against overtemperature using thermal protection thermostats (accessory).

The unit trips when an overload or inadmissible operating conditions occur. Find and remedy the cause.



INFO

The relay switching output is executed as a floating changeover contact. This electrical circuit operates according to the quiescent current principle, i.e. the relay drops into a the idle position and deactivates the motor contactor even in case of a sensor break or open circuit.

5.5 Connection of the trigger unit INT69 G



INFO

Connect the trigger unit INT69 G in accordance with the circuit diagram. Protect the trigger unit with a delayed-action fuse (FC2) of max. 4 A. In order to guarantee the protection function, install the trigger unit as the first element in the control power circuit.



ATTENTION

Measure circuit BT1 and BT2 (PTC sensor) must not come into contact with external voltage. This would destroy the trigger unit INT69 G and PTC sensors.

This would destroy the trigger unit INT69 G and PTC sensors.

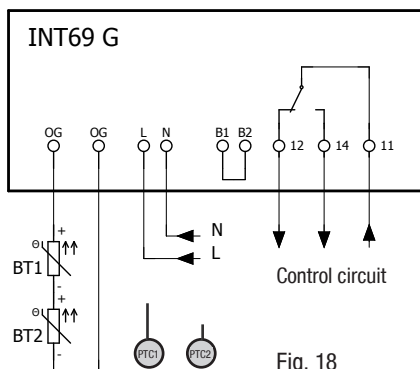
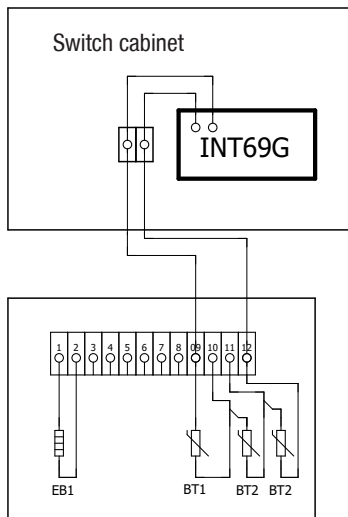

Fig. 18
Terminal box

5 | Electrical connection

5.6 External connection INT69 G



BT1	Cold conductor (PTC sensor) motor winding
BT2	Heat protection thermostat (PTC sensor)
EB1	Oil sump heater

Fig. 19

Terminal box

GB

5.7 Function test of the trigger unit INT69 G

Before commissioning, after troubleshooting or making changes to the control power circuit, check the functionality of the trigger unit. Perform this check using a continuity tester or gauge.

	Gauge state	Relay position
1.	Deactivated state	11-12
2.	INT69 G switch-on	11-14
3.	Remove PTC connector	11-12
4.	Insert PTC connector	11-12
5.	Reset after mains on	11-14

Relay position INT69 G

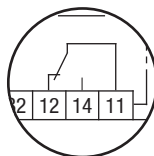

Fig. 20

5| Electrical connection

5.8 Selection and operation of compressors with frequency converters

For safe operation of the compressor, the frequency converter must be able to apply an overload of at least 140% of the compressor's maximum current (I-max.) for at least 3 seconds.

When using frequency converters, the following things must also be observed:

1. The maximum permissible operating current of the compressor (I-max) (see type plate or technical data) must not be exceeded.
2. If abnormal vibrations occur in the system, the affected frequency ranges in the frequency converter must be blanked out accordingly.
3. The maximum output current of the frequency converter must be greater than the maximum current of the compressor (I-max).
4. After each compressor start, run for at least 1 minute at a minimum frequency of 50 Hz.
5. Carry out all designs and installations in accordance with the local safety regulations and common rules (e.g. VDE) and regulations as well as in accordance with the specifications of the frequency converter manufacturer

The permissible frequency range can be found in the chapter 3.3, p. 8.

Rotational speed range	0 - f-min	f-min - f-max
Start-up time	< 1 s	ca. 4 s
Switch-off time	immediately	

GB

6| Commissioning

6.1 Preparations for start-up



INFO!

To protect the compressor against inadmissible operating conditions, high pressure and low pressure pressostats are mandatory on the installation side.

The compressor has undergone trials in the factory and all functions have been tested. There are therefore no special running-in instructions.

Check the compressor for transport damage!

6.2 Pressure strength test

The compressor has been tested in the factory for pressure integrity. If however the entire system is to be subjected to a pressure integrity test, this should be carried out in accordance with EN 378-2 or a corresponding safety standard **without the inclusion of the compressor**.

6.3 Leak test



DANGER!

Risk of bursting!

The compressor must only be pressurised using nitrogen (N₂). Never pressurise with oxygen or other gases!

The maximum permissible overpressure of the compressor must not be exceeded at any time during the testing process (see name plate data)! Do not mix any refrigerant with the nitrogen as this could cause the ignition limit to shift into the critical range.

GB

- Carry out the leak test on the refrigerating plant in accordance with EN 378-2 or a corresponding safety standard, while always observing the maximum permissible overpressure for the compressor.

6.4 Evacuation



ATTENTION! Do not start the compressor if it is under vacuum. Do not apply any voltage even for test purposes (may be operated only with refrigerant).

Under vacuum, the spark-over and creepage current distances of the terminal board connection bolts shorten; this can lead to winding and terminal board damage.

- First evacuate the **system** and then include **the compressor in the evacuation process**.
- Relieve the compressor pressure.
- Open the suction and discharge line valves.
- Evacuate the suction and high pressure sides using the vacuum pump.
- At the end of the evacuation process, the vacuum should be < 1.5 mbar when the pump is switched off.
- Repeat the process as often as is required.

6 | Commissioning

6.5 Refrigerant charge



CAUTION! Wear personal protective clothing such as goggles and protective gloves!

Make sure that the suction and discharge line valves are open.

- With the compressor switched off, add the liquid refrigerant directly to the condenser or receiver, breaking the vacuum.
- If the refrigerant needs topping up after starting the compressor, it can be topped up in vapour form on the suction side, or, taking suitable precautions, also in liquid form at the inlet to the evaporator.



INFO!

- **Avoid overfilling the system with refrigerant!**
- **To avoid shifts in concentration, zeotropic refrigerant blends (e.g. R407C) must always only be filled into the refrigerating plant in liquid form.**
- **Do not pour liquid coolant through the suction line valve on the compressor.**
- **It is not permissible to mix additives with the oil and refrigerant.**

6.6 Start-up



WARNING! Ensure that both shut-off valves are open before starting the compressor!

- Check that the safety and protection devices (pressure switch, motor protection, electrical contact protection measures, etc.) are all functioning properly.
- Switch on the compressor and allow to run for a minimum of 10 min.
- **Check the oil level by:** The oil must be visible in the sightglass.



ATTENTION! If larger quantities of oil have to be topped up, there is a risk of oil hammer effects. If this is the case check the oil return!

6.7 Avoiding liquid sluggings



ATTENTION! Slugging can damage the compressor and cause coolant to leak.

To prevent slugging:

- The complete refrigeration system must be properly designed.
- All components must be compatibly rated with each other with regard to output (particularly the evaporator and expansion valves).
- Suction gas superheat at the compressor input **should be min. 7 - 10 K.** (check the setting of the expansion valve).
- The system must reach a state of equilibrium.
- Particularly in critical systems (e.g. several evaporator points), measures are recommended such as replacement of liquid traps, solenoid valve in the liquid line, etc.
There should be no movement of refrigerant in the compressor while the system is at a standstill.

7 | Maintenance

7.1 Preparation



- WARNING!** Before starting any work on the compressor:
- Switch off the compressor and secure it to prevent a restart.
 - Relieve compressor of system pressure.
 - Prevent air from infiltrating the system!
- After maintenance has been performed:
- Connect safety switch.
 - Evacuate compressor.
 - Release switch lock.

7.2 Work to be carried out

- **Oil change:** In principle, an oil change is not mandatory if the system is correctly manufactured and operated.
However, based on decades of experience we recommend that the following oil change/service work is carried out:
 - First oil change during the first maintenance system.
 - Then after every 10,000–12,000 operating hours, though no more than 3 years, cleaning oil and suction filter at the same time.
- **Annual checks:** Oil level, tightness, running noise, pressures, temperatures, function of auxiliary devices such as a oil sump heater, pressure switch.

GB

7.3 Spare parts recommendation/accessories

Available spare parts and accessories can be found on our compressor selection tool under vap.bock.de as well as at bockshop.bock.de.

Only use genuine Bock spare parts!

7.4 Lubricants / oil

The oil type filled as standard in the factory is marked on the **name plate**, and this should always be used, even in the case of maintenance units. **Alternative oil types** can vary significantly in quality due to additives or inferior raw materials by the manufacturer. Validation within the compressors entire operating limits can not be guaranteed, if such alternative oil types are used. It is for this reason, that we only recommend the use of oil from Bock! Bock assumes no liability for any damage arising from alternative oil types.

Refrigerants	Bock standard oil types
HFKW (z.B. R134a, R407, R404A, R513A)	BOCK lub E55

7.5 Decommissioning

Close the shut-off valve on the compressor. Drain the refrigerant (it must not be discharged directly into the environment) and dispose of it according to the regulations. When the compressor is depressurised, undo the fastening screws of the shut-off valves. Remove the compressor using an appropriate hoist. Dispose of the oil inside in accordance with the valid national regulations.

8 | Technical data

Type	No. of cylinders	Displacement 50 / 60 Hz (1450 / 1740 rpm)	Electrical data ^③				Weight		Connections ^④		Oil charge
			Voltage ^①	Max. Working current ^② Δ / Y	Max. power consump- tion ^②	Starting current (rotor locked) Δ / Y	kg	mm (inch)	Discharge line DV	Suction line SV	
HG22(e)(P)/125-4 A		m ³ /h		A	kW	A	kg	mm (inch)	mm (inch)	Ltr.	
		11,1 / 13,3	220-240 V Δ / 380-420 V Y - 3 - 50 Hz 265-290 V Δ / 440-480 V Y - 3 - 60 Hz	9,3 / 5,4	3,0	69 / 40	44				
HG22(e)(P)/125-4 SA		11,1 / 13,3		10,8 / 6,2	3,6	69 / 40	46				
HG22(e)(P)/160-4 A		13,7 / 16,4		11,1 / 6,4	3,7	69 / 40	46				
HG22(e)(P)/160-4 SA	2	13,7 / 16,4		13,1 / 7,6	4,4	87 / 50	47	16 ^(5/8)	22 ^(7/8)	1,0	
HG22(e)(P)/190-4 A		16,5 / 19,8		13,8 / 8,0	4,8	69 / 40	45				
HG22(e)(P)/190-4 SA		16,5 / 19,8		16,2 / 9,4	5,6	87 / 50	47				

^① Tolerance (± 10%) relative to the mean value of the voltage range.

Other voltages and types of current on request.

^② - The specifications for max. power consumption apply for 50Hz operation.

For 60Hz operation, the specifications have to be multiplied by the factor

1.2. The max. working current remains unchanged.

- Take account of the max. operating current / max. power consumption for design of fuses, supply lines and safety devices.

Fuse: Consumption category AC3

^③ All specifications are based on the average of the voltage range

^④ For solder connections

9 | Dimensions and connections

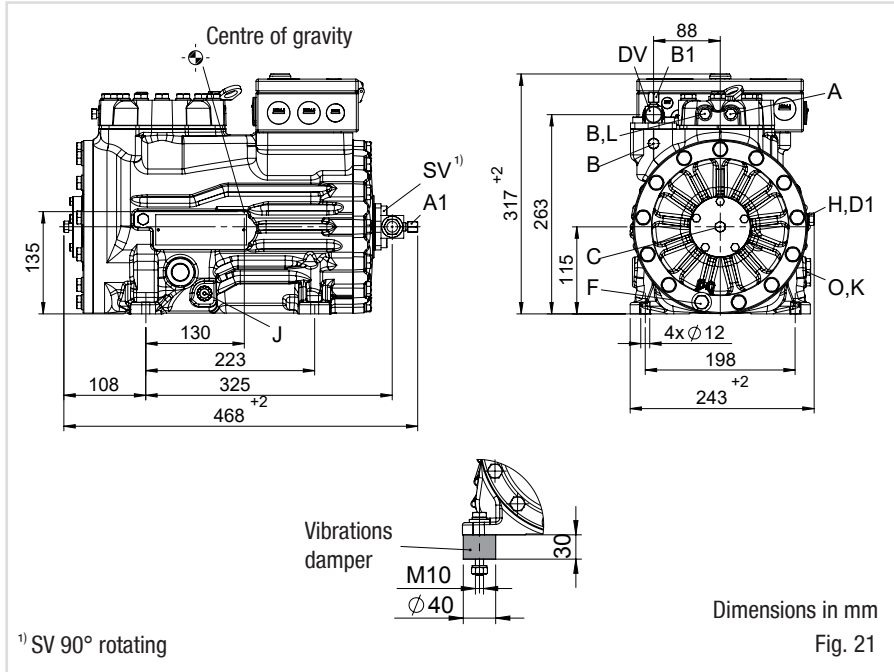

GB

SV	Suction line	see technical data, Chapter 8	
DV	Discharge line		
A*	Connection suction side, not lockable		1/8" NPTF
A1	Connection suction side, lockable		7/16" UNF
B	Connection discharge side, not lockable		1/8" NPTF
B1	Connection discharge side, lockable		7/16" UNF
C	Connection oil pressure safety switch		1/8" NPTF
D1	Connection oil return from oil separator		1/4" NPTF
F	Oil drain		M10
H	Oil charge plug		1/4" NPTF
J	Connection oil sump heater		3/8" NPTF
K	Sight glass		1 1/8" - 18 UNEF
L	Connection thermal protection thermostat		1/8" NPTF
O	Connection oil level regulator		1 1/8" - 18 UNEF

* The LP connection on the cylinder cover must not be used for the low-pressure switch in capacity-controlled operation.

10 | Declaration of incorporation

Declaration of incorporation for incomplete machinery in accordance with EC Machinery Directive 2006/42/EC, Annex II 1. B

Manufacturer: Bock GmbH
Benzstraße 7
72636 Frickenhausen, Germany

We, as manufacturer, declare in sole responsibility that the incomplete machinery

Name: Semi-hermetic compressor
Types: HG(X)12P/60-4 S (HC) HG(X)88e/3235-4(S) (HC)
UL-HGX12P/60 S 0,7 UL-HGX66e/2070 S 60
HGX12P/60 S 0,7 LG HGX88e/3235 (ML/S) 95 LG
HG(X)22(P)(e)/125-4 A HG(X)34(P)(e)/380-4 (S) A
HGX34(P)(e)/255-2 (A) HGX34(P)(e)/380-2 (A)(K)
HA(X)12P/60-4 HA(X)6/1410-4
HAX22e/125 LT 2 LG HAX44e/665 LT 14 LG
HGX12e/20-4 (ML/S) CO₂ (LT) HGX44e/565-4 S CO₂
UL-HGX12e/20 (S/ML) 0,7 CO₂ (LT)... UL-HGX44e/565 S 31 CO₂
HGX12/20-4 (ML/S/SH) CO₂T HGX46/440-4 (ML/S/SH) CO₂ T
UL-HGX12/20 ML(P) 2 CO₂T UL-HGX46/440 ML(P) 53 CO₂T
HGZ(X)7/1620-4 HGZ(X)7/2110-4
HGZ(X)66e/1340 LT 22 HGZ(X)66e/2070 LT 35
HRX40-2 CO₂ T H HRX60-2 CO₂ T H

Name: Open type compressor
Types: F(X)2 F(X)88/3235 (NH3)
FK(X)1 FK(X)3
FK(X)20/120 (K/N/TK) FK(X)50/980 (K/N/TK)

Serial number: BC00000A001 – BN99999Z999

complies with the following provisions of the above-mentioned Directive:

According to Annex I, points 1.1.2, 1.1.3, 1.1.5, 1.3.2, 1.3.3, 1.3.7, 1.5.1, 1.5.2, 1.5.13 and 1.7.1 to 1.7.4 (excepted 1.7.4 f) are fulfilled.

Applied harmonised standards, in particular:

EN ISO 12100 :2010 Safety of machinery — General principles for design — Risk assessment and risk reduction
EN 12693 :2008 Refrigerating systems and heat pumps — Safety and environmental requirements — Positive displacement refrigerant compressors

Remarks: We also declare that the special technical documentation for this incomplete machine has been created in accordance with Annex VII, Part B and we obligate to provide these upon reasoned request from the individual national authorities by data transfer.

Commissioning is prohibited until it has been confirmed that the machinery into which the incomplete machine above is to be incorporated complies with the EC Machinery Directive and an EC Declaration of Conformity, Annex II. 1. A exists.

Authorized person for compiling and handing
over technical documentation:

Bock GmbH
Alexander Layh
Benzstraße 7
72636 Frickenhausen, Germany

Frickenhausen, 04th of January 2021



i. A. Alexander Layh, Global Head of R&D

10 | Declaration of incorporation

Declaration of incorporation of partly completed machinery in accordance with UK Statutory Instrument Supply of Machinery (Safety) Regulations 2008, Annex II 1. B

Manufacturer: Bock GmbH
Benzstraße 7
72636 Frickenhausen, Germany



We, as manufacturer, declare in sole responsibility that the partly completed machinery

Name: Semi-hermetic compressor

Types: HG(X)12P/60-4 S (HC) HG(X)88e/3235-4(S) (HC)
UL-HGX12P/60 S 0,7 UL-HGX66e/2070 S 60
HGX12P/60 S 0,7 LG HGX88e/3235 (ML/S) 95 LG
HG(X)22(P)(e)/125-4 A HG(X)34(P)(e)/380-4 (S) A
HGX34(P)(e)/255-2 (A) HGX34(P)(e)/380-2 (A)(K)
HA(X)22e/125-4 HA(X)6/1410-4
HAX22e/125 LT 2 LG HAX44e/665 LT 14 LG
HGX12e/20-4 (ML/S) CO₂ (LT) HGX44e/565-4 S CO₂
UL-HGX12e/20 (S/ML) 0,7 CO₂ (LT) ... UL-HGX44e/565 S 31 CO₂
HGX12/20-4 (ML/S/SH) CO₂T HGX46/440-4 (ML/S/SH) CO₂ T
UL-HGX12/20 ML(P) 2 CO₂T UL-HGX46/440 ML(P) 53 CO₂T
HGZ(X)7/1620-4 HGZ(X)7/2110-4
HGZ(X)66e/1340 LT 22 HGZ(X)66e/2070 LT 35
HRX40-2 CO₂ T H HR(Z)X60-2 CO₂ T (H)(V)

Name: Open type compressor

Types: F(X)2 F(X)88/3235 (NH3)
FK(X)1 FK(X)3
FK(X)20/120 (K/N/TK) FK(X)50/980 (K/N/TK)

Serial number: BC00000A001 – BN99999Z999



complies with the following provisions of the above-mentioned Statutory instrument:

According to Schedule 2, part1, points 1.1.2, 1.1.3, 1.1.5, 1.3.2, 1.3.3, 1.3.7, 1.5.1, 1.5.2, 1.5.13 and 1.7.1 to 1.7.4 (excepted 1.7.4 f) are fulfilled.

Designated standards: EN ISO 12100 :2010 Safety of machinery — General principles for design — Risk assessment and risk reduction
EN 12693 :2008 Refrigerating systems and heat pumps — Safety and environmental requirements — Positive displacement refrigerant compressors

Remarks: We also declare that the special technical documentation for this partly completed machine has been created in accordance with Annex II, 1. B and we obligate to provide these upon reasoned request from the individual national authorities by data transfer.

Commissioning is prohibited until it has been confirmed that the machinery into which the partly completed machine above is to be incorporated complies with the UK Statutory Instrument Supply machinery (Safety) regulations 2008 and an EC Declaration of Conformity, Annex II, 1. A exists.

Authorized person for compiling and handing over technical documentation:

Bock GmbH
Alexander Layh
Benzstraße 7
72636 Frickenhausen, Germany

Frickenhausen, 14th of October 2022

i. A. Alexander Layh, Global Head of R&D

GB

ENGINEERING
TOMORROW



Danfoss A/S
Climate Solutions • danfoss.com • +45 7488 2222

Any information, including, but not limited to information on selection of product, its application or use, product design, weight, dimensions, capacity or any other technical data in product manuals, catalogues descriptions, advertisements, etc. and whether made available in writing, orally, electronically, online or via download, shall be considered informative, and is only binding if and to the extent, explicit reference is made in a quotation or order confirmation. Danfoss cannot accept any responsibility for possible errors in catalogues, brochures, videos and other material. Danfoss reserves the right to alter its products without notice. This also applies to products ordered but not delivered provided that such alterations can be made without changes to form, fit or function of the product.
All trademarks in this material are property of Danfoss A/S or Danfoss group companies. Danfoss and the Danfoss logo are trademarks of Danfoss A/S. All rights reserved.