

# BOCK® HA44e (LG)

## Operating guide

HA44e/475-4  
HA44e/565-4  
HA44e/665-4

HAX44e/475-4  
HAX44e/565-4  
HAX44e/665-4

HAX44e/475 LT 9 LG  
HAX44e/565 LT 12 LG  
HAX44e/665 LT 14 LG

# About these instructions

Read these instructions before assembly and before using the compressor. This will avoid misunderstandings and prevent damage. Improper assembly and use of the compressor can result in serious or fatal injury.

Observe the safety instructions contained in these instructions.

These instructions must be passed onto the end customer along with the unit in which the compressor is installed.

GB

## Contents

Page

<b>1</b>	<b>Safety</b>	<b>4</b>
1.1	Identification of safety instructions	
1.2	Qualifications required of personnel	
1.3	General safety instructions	
1.4	Intended use	
<b>2</b>	<b>Safety instructions for use of flammable refrigerants</b>	<b>6</b>
2.1	Safety instructions	
2.2	Qualifications required of personnel	
<b>3</b>	<b>Product description</b>	<b>7</b>
3.1	Short description	
3.2	Name plate	
3.3	Type key	
3.4	Type key LG compressors	
<b>4</b>	<b>Areas of application</b>	<b>10</b>
4.1	Refrigerants	
4.2	Oil charge	
4.3	Limits of application	

# Contents

Page

<b>5</b>	<b>Areas of application at LG compressors</b>	<b>11</b>
5.1	Refrigerants	
5.2	Oil charge	
5.3	Limits of application	
<b>6</b>	<b>Compressor assembly</b>	<b>12</b>
6.1	Storage and transport	
6.2	Setting up	
6.3	Pipe connections	
6.4	Pipes	
6.5	Laying suction and pressure lines	
6.6	Operating the shut-off valves	
6.7	Operating mode of the lockable service connections	
6.8	Suction pipe filter and filter drier	
<b>7</b>	<b>Electrical connection</b>	<b>16</b>
7.1	Information for contactor and motor contactor selection	
7.2	Standard motor, design for direct or partial winding start	
7.3	Basic circuit diagram for partial winding start with standard motor	
7.4	Special motor: design for direct or star-delta start	
7.5	Basic circuit diagram for star-delta start with special motor	
7.6	Electronic trigger unit INT69 G	
7.7	Connecting of the trigger unit INT69 G	
7.8	Functional test of the trigger unit INT69 G	
7.9	Electronic trigger unit INT69 G on LG compressors	
7.10	Oil sump heater (accessories)	
7.11	Oil sump heater on LG compressors	
7.12	Capacity regulator (accessories)	
7.13	Fan motor	
7.14	Selection and operation of compressors with frequency converters	
<b>8</b>	<b>Commissioning</b>	<b>28</b>
8.1	Preparations for start-up	
8.2	Pressure integrity test	
8.3	Leak test	
8.4	Evacuation	
8.5	Refrigerant charge	
8.6	Start-up	
8.7	Avoid slugging	
8.8	Connection of oil level regulator	
<b>9</b>	<b>Maintenance</b>	<b>31</b>
9.1	Preparation	
9.2	Work to be carried out	
9.3	Spare parts recommendation/accessories	
9.4	Lubricants / oil	
9.5	Decommissioning	
9.6	Additional information when using flammable refrigerants	
<b>10</b>	<b>Accessories</b>	<b>33</b>
10.1	Capacity regulator	
<b>11</b>	<b>Technical data</b>	<b>35</b>
<b>12</b>	<b>Dimensions and connections</b>	<b>36</b>
<b>13</b>	<b>Declaration of incorporation</b>	<b>37</b>

GB

# 1 | Safety

## 1.1 Identification of safety instructions:



**DANGER**

Indicates a dangerous situation which, if not avoided, will cause immediate fatal or serious injury.



**WARNING**

Indicates a dangerous situation which, if not avoided, may cause fatal or serious injury.



**CAUTION**

Indicates a dangerous situation which, if not avoided, may cause fairly severe or minor injury.



**ATTENTION**

Indicates a situation which, if not avoided, may cause property damage.



**INFO**

Important information or tips on simplifying work.

GB

## 1.2 Qualifications required of personnel



**WARNING**

Inadequately qualified personnel poses the risk of accidents, the consequence being serious or fatal injury. Work on compressors is therefore reserved for personnel which is qualified to work on pressurized refrigerant systems:

- For example, a refrigeration technician, refrigeration mechatronic engineer. As well as professions with comparable training, which enables personnel to assemble, install, maintain and repair refrigeration and air-conditioning systems. Personnel must be capable of assessing the work to be carried out and recognising any potential dangers.

# 1| Safety

## 1.3 General safety instructions



### WARNING

**Risk of accidents.**

Refrigerating compressors are pressurised machines and as such call for heightened caution and care in handling.

The maximum permissible overpressure must not be exceeded, even for testing purposes.

**Risk of burns!**

- Depending on the operating conditions, surface temperatures of over 60°C on the discharge side or below 0°C on the suction side can be reached.

- Avoid contact with refrigerant necessarily.

Contact with refrigerant can cause severe burns and skin damage.

## 1.4 Intended use



### WARNING

**The compressor may not be used in potentially explosive environments!**

GB

These assembly instructions describe the standard version of the compressor named in the title manufactured by Bock. Bock refrigerating compressors are intended for installation in a machine (within the EU according to the EU Directives 2006/42/EC Machinery Directive, 2014/68/EU Pressure Equipment Directive).

Commissioning is permissible only if the compressor has been installed in accordance with these assembly instructions and the entire system into which it is integrated has been inspected and approved in accordance with legal regulations.

The compressors are intended for use in refrigeration systems in compliance with the limits of application.

Only the refrigerant specified in these instructions may be used.

**Any other use of the compressor is prohibited!**

# 2 | Safety instructions for use of flammable refrigerants

## 2.1 Safety instructions



### DANGER

- Explosion and fire risk! Synthetic HFO refrigerants are colourless, combustible gases which occur naturally and which are explosive in a certain blend!
- HFO refrigerants are classified into the safety group A2L (hardly-inflammable refrigerant) according to EN 378.

As they are heavier than air, the operating location must be above ground level to allow unrestricted discharge of the gas.

- By means of a risk and hazard analysis, appropriate technical measures are to be identified in order to achieve sufficient risk reduction. If necessary, a classification of the hazardous areas according to EN60079-10-1 should be carried out. If the refrigerant concentration exceeds the value of 25% of the lower flammability limit (LEL), all equipment in the hazardous area which is not permitted for operation in hazardous areas must be immediately switched off without any voltage.
- Use only suitable equipment approved for flammable refrigerants.
- Observe the national regulations.



### INFO

Semi-hermetic compressors are to be classified as "technically tight" (see e.g. TRBS 2152 part 2 / TRGS 722).

## 2.2 Qualifications required of personnel



### WARNING

Inadequately qualified personnel poses the risk of accidents, the consequence being serious or fatal injury. Work on compressors is therefore reserved for personnel which is qualified in handling flammable refrigerants.

# 3 | Product description

## 3.1 Short description

- Semi-hermetic four-cylinder reciprocating compressor with oil pump lubrication.
- Flange-mounted drive motor on the compressor case.
- Specially or deep cooling with air-cooled motor and direct suction at the cylinder.

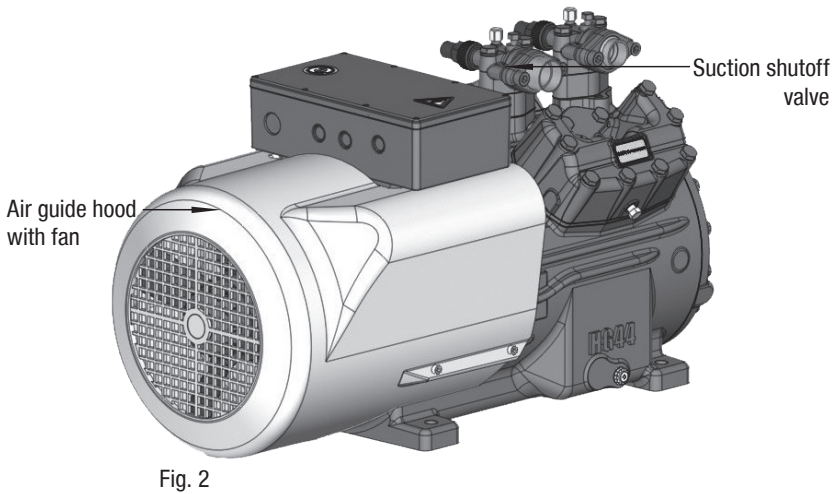
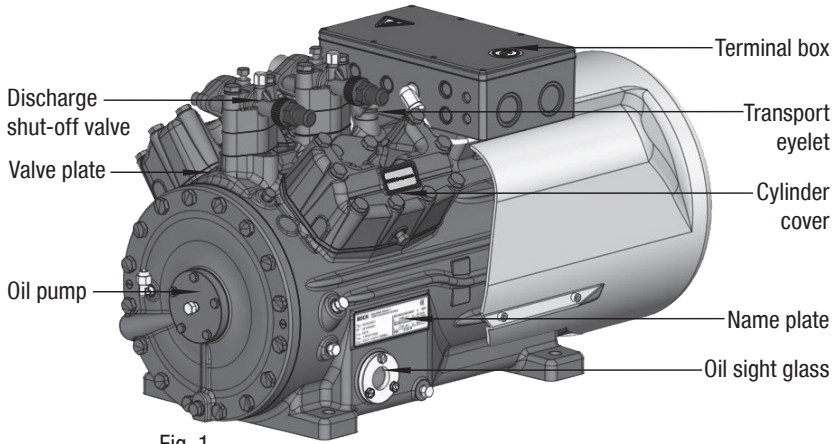

Dimension and connection values can be found in Chapter 12.

GB

# 3 | Product description

## 3.2 Name plate (example)

<b>BOCK</b>		Bock GmbH, Benzstr. 7 72636 Frickenhausen, Germany		<b>CE</b>	
1	Typ : HA44e/665-4	380-420 V Y/YY	-3-	50HZ	6
2	Nr. : AZ12345A001	n : 1450 min <sup>-1</sup>	V <sub>th.</sub> : 57,7 m <sup>3</sup> /h		7
3	I <sub>max</sub> : 20,3 A	440-480 V Y/YY	-3-	60HZ	8
4	I <sub>block.</sub> Y: 101 A YY: 174 A	n : 1740 min <sup>-1</sup>	V <sub>th.</sub> : 69,2 m <sup>3</sup> /h		9
5	p <sub>max</sub> : ND(LP) / HD(HP)=19/28 bar	IP44	Ö:BOCKlub E55		10
					11
					12
					13

Fig. 3

1	Type designation	6	Voltage, circuit, frequency	} 50 Hz
2	Machine number	7	Nominal rotation speed	
3	maximum operating current	8	Displacement	} 60 Hz
4	Starting current (rotor blocked)	9	Voltage, circuit, frequency	
	Y: Part winding 1 YY: Part windings 1 and 2	10	Nominal rotation speed	
5	ND (LP): max. admissible operating pressure Low pressure side	11	Displacement	
	HD (HP): max. admissible operating pressure High pressure side	12	Oil type filled at the factory	
		13	Protection class	

**i** Observe the limits of application diagrams!

**i** Electrical accessories can change the IP protection class!

## 3.3 Type key (example)

**HA X 44 e / 665-4**

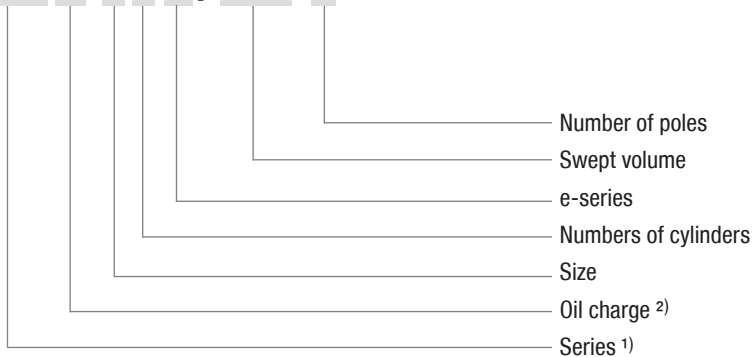

<sup>1)</sup> HA - Hermetic Air-cooled for deep-freezing

<sup>2)</sup> X - Ester oil charge (HFC refrigerant, e.g. R404A/R507)

GB

# 3 | Product description

## 3.4 Typ key LG compressor (example)

**HA X 44 e / 475 LT 9 LG**

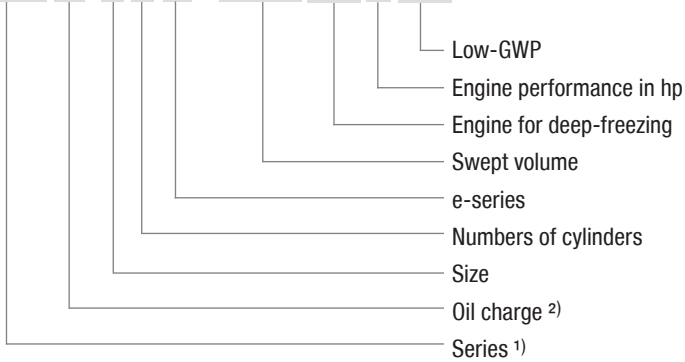

<sup>1)</sup> HA - Hermetic Air-cooled for deep-freezing

<sup>2)</sup> X - Ester oil charge

# 4 | Areas of application

## 4.1 Refrigerants

- HFKW / HFC: R404A/R507
- (H)FCKW / (H)CFC: R22

## 4.2 Oil charge

- The compressors are filled at the factory with the following oil type:
  - for R404A/R507 **BOCK** lub E55
  - for R22 **BOCK** lub A46

Compressors with ester oil charge (**BOCK** lub E55) are marked with an X in the type designation (e.g. HAX34e/315-4).



### INFO

For refilling, we recommend the above oil types.  
Alternatives: see chapter 9.5



### ATTENTION

The oil level must be in the visible part of the sight glass; damage to the compressor is possible if overfilled or underfilled!

max.  
oil level  
min.

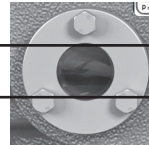

Fig. 4

GB

## 4.3 Limits of application



### ATTENTION

Compressor operation is possible within the operating limits. These can be found in Bock compressor selection tool (VAP) under [vap.bock.de](http://vap.bock.de). Observe the information given there.

- Max. permissible ambient temperature 45°C.
- Max. permissible discharge end temperature 140°C.
- Max. permissible switching frequency 12x /h.
- A minimum running time of 3 min. steady-state condition (continuous operation) must be achieved.

For operation with capacity regulator:

- Continuous operation, when the capacity regulator is activated, is not permissible and can cause damage to the compressor.
- The suction gas superheat temperature may need to be reduced or set individually when operating near to the threshold.
- When the capacity regulator is activated, the gas velocity in the system can not under certain circumstances ensure that sufficient oil is transported back to the compressor.

For operation with frequency converter:

- The maximum current and power consumption must not be exceeded. In the case of operation above the mains frequency, the application limit can therefore be limited.

(For more on the subject of frequency converters, see chapter 7.14, p. 27)

When operating in the vacuum range, there is a danger of air entering on the suction side. This can cause chemical reactions, a pressure rise in the condenser and an elevated compressed-gas temperature. Prevent the ingress of air at all costs!

## 4 | Areas of application

Maximum permissible operating pressure (LP/HP)<sup>1)</sup>: 19/28 bar

<sup>1)</sup> LP = Low pressure HP = High pressure

## 5 | Areas of application at LG compressors

### 5.1 Refrigerants

- HFO refrigerants: R455A, R454C

### 5.2 Oil charge

The compressors are factory-charged with the following oil type:

LG Compressors: **BOCK**lub E55

### 5.3 Limits of application



**ATTENTION** Compressor operation is possible within the operating limits. These can be found in Bock compressor selection tool (VAP) under [vap.bock.de](http://vap.bock.de). Observe the information given there and the following notes:

- Min. pressure gas temperature  $\geq 50^{\circ}\text{C}$  (min. 20K over condensing temperature). Suction gas superheating on compressor entrance should be min. 7 - 10 K, must be increased if necessary
- Min. oil temperature  $\geq 30^{\circ}\text{C}$ .
- Operation in the vacuum range is not permitted.

During operation in the vacuum range, there is a danger of air entering on the suction side. This can cause chemical reactions, pressure rise in the condenser and an excessive pressure gas temperature as well as shifting of the refrigerant ignition limit into the critical range. Avoid absolutely any entry of air!

Use a low pressure switch! Select a shut-off point min. 50 Pa higher than the prevailing surrounding pressure!

Maximum permissible operating pressure (LP/HP)<sup>1)</sup>: 19/32 bar

<sup>1)</sup> LP = Low pressure HP = High pressure

GB

# 6 | Compressor assembly



## INFO

New compressors are factory-filled with inert gas. Leave this service charge in the compressor for as long as possible and prevent the ingress of air. Check the compressor for transport damage before starting any work.

## 6.1 Storage and transport



- Storage at (-30°C) - (+70°C), maximum permissible relative humidity 10% - 95%, no condensation
- Do not store in a corrosive, dusty, vaporous atmosphere or in a combustible environment.



- Use transport eyelet.
- Do not lift manually!
- Use lifting gear!

## 6.2 Setting up



## ATTENTION

Attachments (e.g. pipe holders, additional units, fastening parts, etc.) directly to the compressor are not permissible!

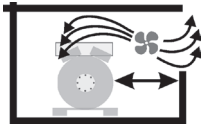

- Provide adequate clearance for maintenance work.
- Ensure adequate compressor ventilation.  
The compressor must not be in the air stream to another component of the refrigeration system (e.g. condenser).  
The cooling of the drive motor must be reliable guaranteed.



- Do not use in a corrosive, dusty, damp atmosphere or a combustible environment.

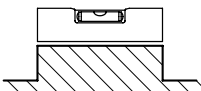

- Setup on an even surface or frame with sufficient load-bearing capacity.
- Single compressor preferably on vibration damper.
- Duplex and parallel circuits always rigid.



- Sun protection: If the compressor is set up outdoors, it has to be protected from direct sunlight.

# 6 | Compressor assembly

## 6.3 Pipe connections



**ATTENTION** **Damage possible.**  
**Superheating can damage the valve.**  
**Remove the pipe supports from the valve for soldering.**  
**Only solder using inert gas to inhibit oxidation products (scale).**

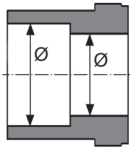

Fig. 5: graduated internal diameter

- The **pipe connections** have graduated inside diameters so that pipes with standart millimetre and inch dimensions can be used.
- The connection diameters of the shut-off valves are rated for maximum compressor output. **The actual required pipe cross section must be matched to the output. The same applies for non-return valves.**

## 6.4 Pipes

- Pipes and system components must be clean and dry inside and free of scale, swarf and layers of rust and phosphate. Only use air-tight parts.
- Lay pipes correctly. Suitable vibration compensators must be provided to prevent pipes being cracked and broken by severe vibrations.
- Ensure a proper oil return.
- Keep pressure losses to an absolute minimum.

GB

## 6.5 Laying suction and pressure lines



**ATTENTION** **Improperly installed pipes can cause cracks and tears, the result being a loss of refrigerant.**



**INFO** **Proper layout of the suction and discharge lines directly after the compressor is integral to the system's smooth running and vibration behaviour.**

# 6 | Compressor assembly

**A rule of thumb:** Always lay the first pipe section starting from the shut-off valve **downwards and parallel to the drive shaft**.

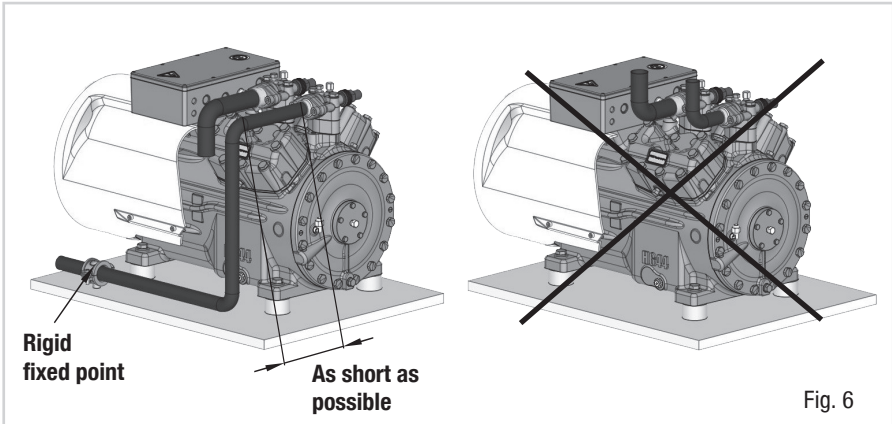

GB

## 6.6 Operating the shut-off valves

- Before opening or closing the shut-off valve, release the valve spindle seal by approx.  $\frac{1}{4}$  of a turn counter-clockwise.
- After activating the shut-off valve, re-tighten the adjustable valve spindle seal clockwise.

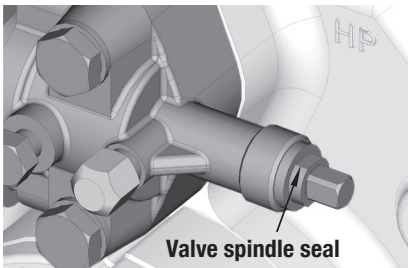

Fig. 7

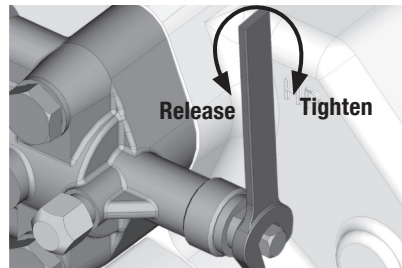

Fig. 8

# 6 | Compressor assembly

## 6.7 Operating mode of the lockable service connections

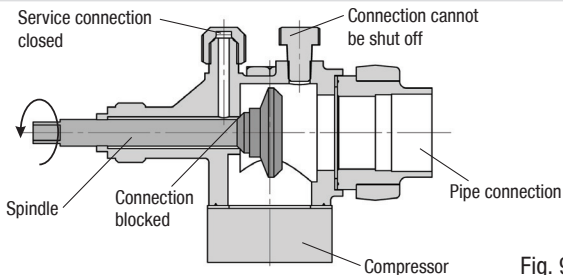

Fig. 9

### Opening the shut-off valve:

Spindle: turn to the left (counter-clockwise) as far as it will go.

—> Shut-off valve completely opened / service connection closed.

The connection which cannot be shut off is intended for safety devices.

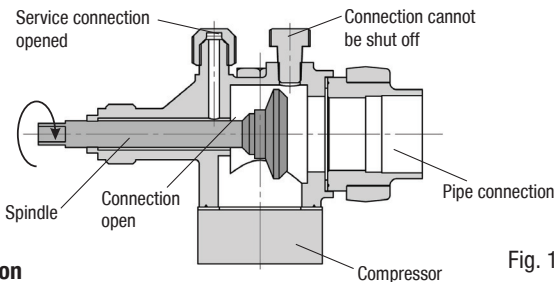

Fig. 10

### Opening the service connection

Spindle: Turn 1/2 - 1 turn to the right clockwise.

—> Service connection opened / shut-off valve opened.

The connection which cannot be shut off is intended for safety devices.

GB

After activating the spindle, generally fit the spindle protection cap again and tighten with 14-16 Nm. This serves as a second sealing feature during operation.

## 6.8 Suction pipe filter and filter drier

For systems with long pipes and higher degree of contamination, a filter on the suction-side is recommended. The filter has to be renewed depending on the degree of contamination (reduced pressure loss).

Moisture in the refrigeration circuit can lead to crystal and hydrate formation. For this reason, we recommend using a filter drier and a sight glass with a moisture indicator.

# 7 | Electrical connection

## 7 Electrical connection



### DANGER

**Risk of electric shock! High voltage!**

**Only carry out work when the electrical system is disconnected from the power supply!**



### ATTENTION

**When attaching accessories with an electrical cable, a minimum bending radius of 3 x the cable diameter must be maintained for laying the cable.**



### INFO

Connect the compressor motor in accordance with the circuit diagram (see inside of terminal box).

- Use suitable cable entry point of the correct protection type (see name plate) for routing cables into the terminal box. Insert the strain reliefs and prevent chafe marks on the cables.
- Compare the voltage and frequency values with the data for the mains power supply.

**Only connect the motor if these values are the same.**

GB

### 7.1 Information for contactor and motor contactor selection

All protection equipment, switching and monitoring devices must comply with the local safety regulations and established specifications (e.g. VDE) and regulations as well as the manufacturer's specifications. **Motor protection switches are required!** Motor contactors, feed lines, fuses and motor protection switches must be rated according to the maximum operating current (see name plate). For motor protection, use a current-independent, time-delayed overload protection device for monitoring all three phases. Adjust the overload protection device so that it must be actuated within 2 hours at 1.2 times the maximum working current.

# 7 | Electrical connection

## 7.2 Standard motor, design for direct or partial winding start

Designation on the name plate
<b>Y/YY</b>

Compressors with this marking are suitable for direct or partial winding start. The motor winding is subdivided into two parts: **Part winding 1 = 50% and part winding 2 = 50%**. This winding division reduces the start-up current needed for a part winding start to approx. 50% of that for a direct start.



**INFO**

**A mechanical unloaded start with bypass solenoid valve is not required.**

### 7.3 Basic circuit diagram for partial winding start with standard motor

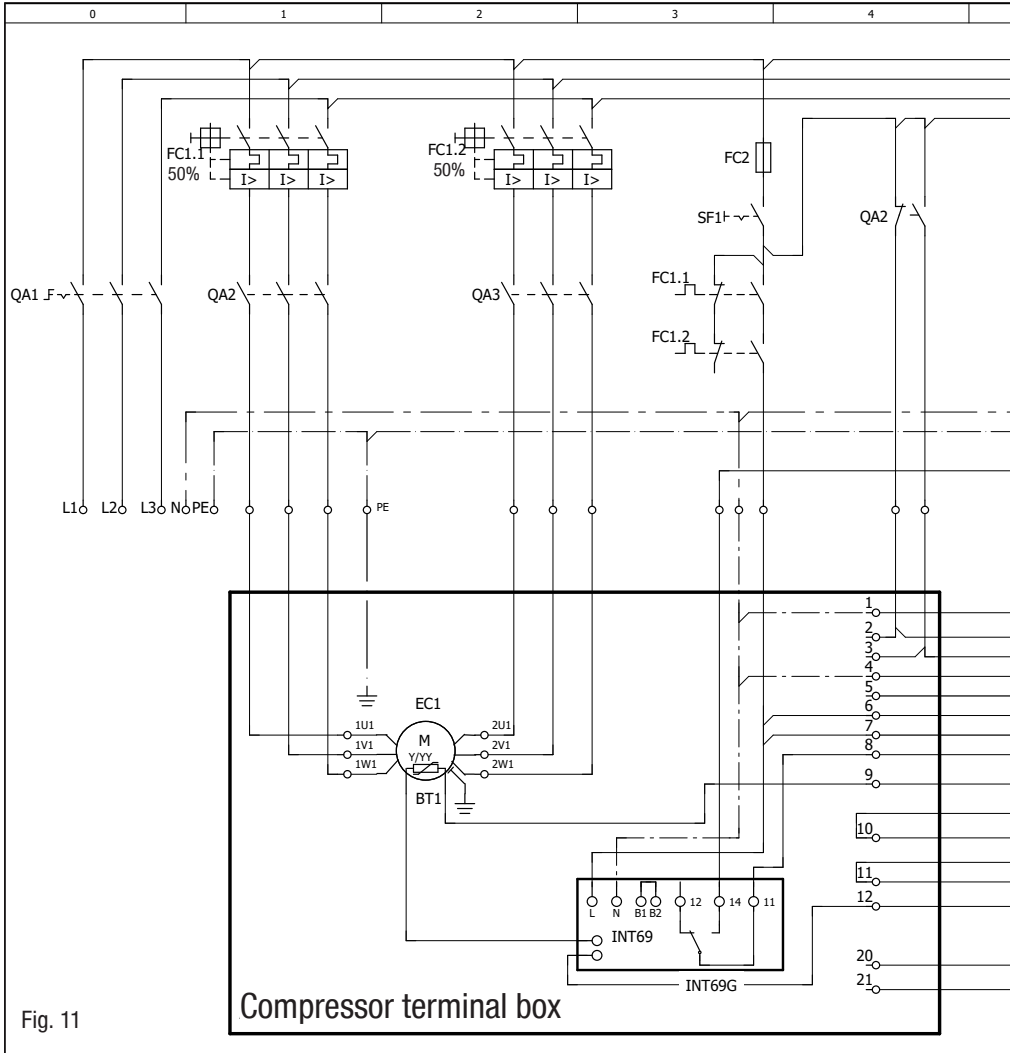
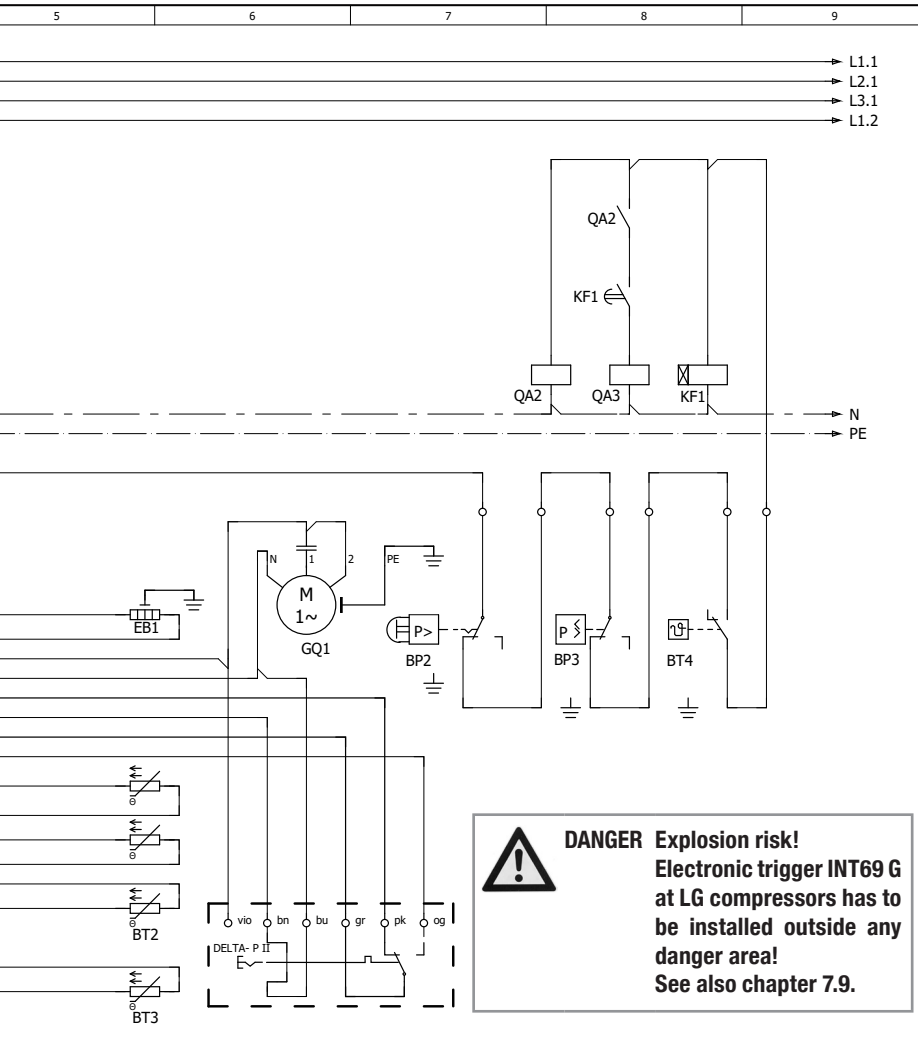

Fig. 11

Compressor terminal box

BP2	High pressure safety monitor
BP3	Safety chain (high/low pressure monitoring)
BT1	Cold conductor (PTC sensor) motor winding
BT2	Thermal protection thermostat (PTC sensor)
BT3	Oil temperature sensor
BT4	Release switch (thermostat)
DELTA-P II	Oil differential pressure sensor DELTA-P II (accessorie)
EB1	Oil sump heater
EC1	Compressor motor



GB

FC1.1/1.2	Motor protection switch
FC2	Control power circuit fuse
GQ1	Fan motor
INT69 G	Electronic trigger unit INT69 G
KF1	Delay relay for contactor switchover
QA1	Main switch
QA2	Mains contactor (part winding 1)
QA3	Mains contactor (part winding 2)
SF1	Control voltage switch

# 7 | Electrical connection

The motor is wired for direct start (YY) at the factory. For part winding start Y / YY, the bridges must be removed and the motor feed line connected according to the circuit diagram:

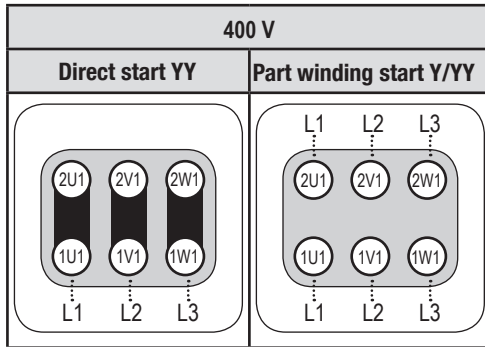

**ATTENTION** Failure to do this results in opposed rotary fields and results in damage to the motor. After the motor starts up via partial winding 1, partial winding 2 must be switched on after a maximum delay of one second. Failure to comply can adversely affect the service life of the motor.

GB

# 7 | Electrical connection

## 7.4 Special motor: design for direct or star-delta start

A mechanical unloaded start with bypass solenoid valve (accessories) is required for the star-delta start.

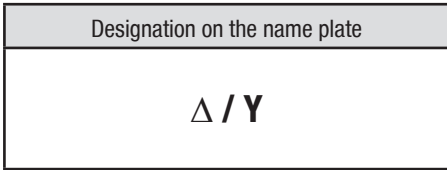

Star-delta start-up is only possible for 230 V power supply. Example:

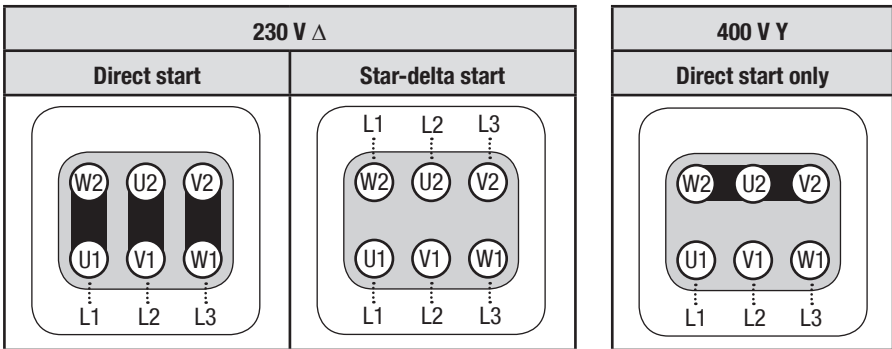

GB

## 7.5 Basic circuit diagram for star-delta start with special motor

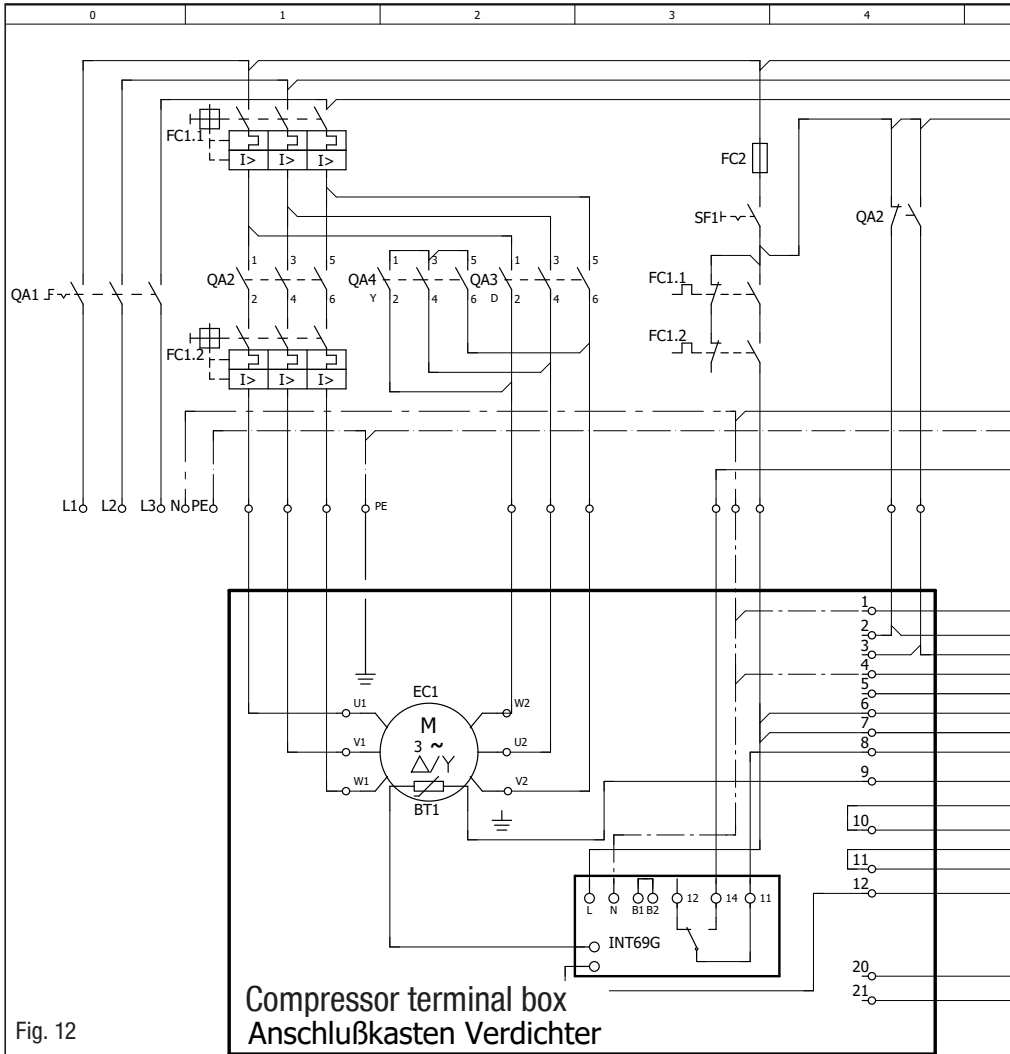
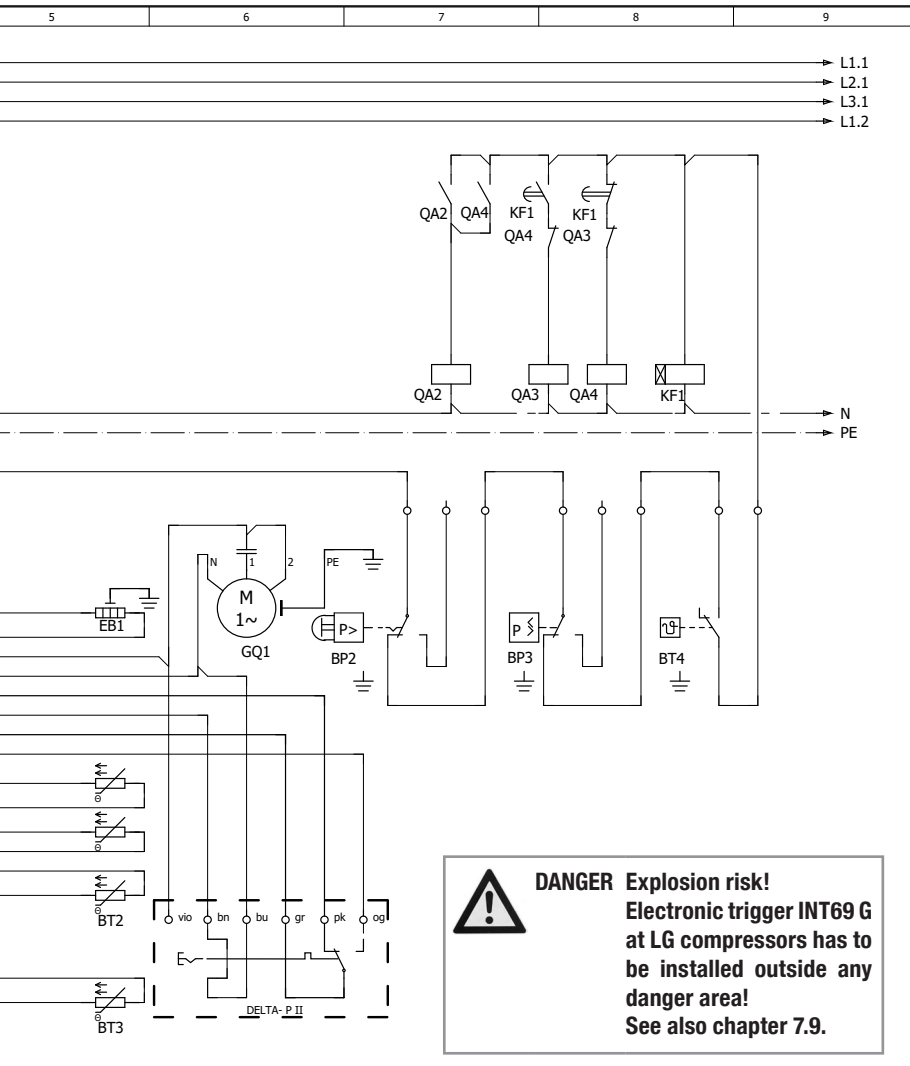

Fig. 12

BP2	High pressure safety monitor
BP3	Safety chain (high/low pressure monitoring)
BT1	Cold conductor (PTC sensor) motor winding
BT2	Thermal protection thermostat (PTC sensor)
BT3	Oil temperature sensor
BT4	Release switch (thermostat)
DELTA PII	Oil differential pressure sensor DELTA-P II (accessories)
EB1	Oil sump heater
EC1	Compressor motor
FC1.1/1.2	Motor protection switch



**GB**

**⚠ DANGER Explosion risk!**  
**Electronic trigger INT69 G at LG compressors has to be installed outside any danger area!**  
**See also chapter 7.9.**

FC2	Control power circuit fuse
GQ1	Fan motor
INT69 G	Electronic trigger unit INT69 G
KF1	Delay relay for contactor switchover
QA1	Main switch
QA2	Mains contactor
QA3	Δ-contactor
QA4	Y-contactor
SF1	Control voltage switch

# 7 | Electrical connection

## 7.6 Electronic trigger unit INT69 G

The compressor motor is fitted with cold conductor temperature sensors (PTC) connected to the electronic trigger unit INT69 G in the terminal box. In case of excess temperature in the motor winding, the INT69 G deactivates the motor contactor. Once cooled, it can be restarted only if the electronic lock of the output relay (terminals B1+B2) is released by interrupting the supply voltage.

The hot gas side of the compressor can also be protected against overtemperature using thermal protection thermostats (accessory).

**The unit trips when an overload or inadmissible operating conditions occur. Find and remedy the cause.**



INFO

The relay switching output is executed as a floating changeover contact. This electrical circuit operates according to the quiescent current principle, i.e. the relay drops into a the idle position and deactivates the motor contactor even in case of a sensor break or open circuit.

## 7.7 Connection of the trigger unit INT69 G



INFO

Connect the trigger unit INT69 G in accordance with the circuit diagram. Protect the trigger unit with a delayed-action fuse (FC2) of max. 4 A. In order to guarantee the protection function, install the trigger unit as the first element in the control power circuit.



**ATTENTION**

Measure circuit BT1 and BT2 (PTC sensor) must not come into contact with external voltage.

This would destroy the trigger unit INT69 G and PTC sensors.

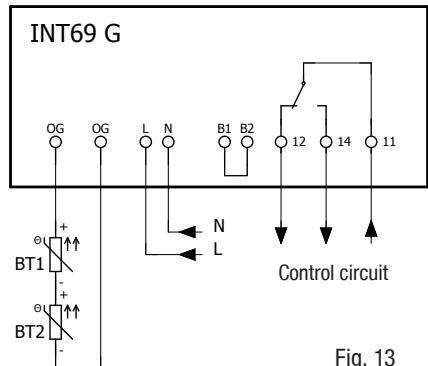

Fig. 13  
Terminal box

# 7 | Electrical connection

## 7.8 Function test of the trigger unit INT69 G

Before commissioning, after troubleshooting or making changes to the control power circuit, check the functionality of the trigger unit. Perform this check using a continuity tester or gauge.

Gauge state	Relay position
Deactivated state	11-12
INT69 G switch-on	11-14
Remove PTC connector	11-12
Insert PTC connector	11-12
Reset after mains on	11-14

Relay position INT69 G

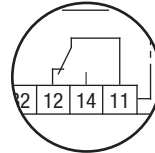

Fig. 14

## 7.9 Electronic trigger unit INT69 G at LG compressors

The supplied INT69 G must be connected according to the wiring diagram shown here in a separate control cabinet, which must be installed outside each danger zone.



**ATTENTION** Install heat protection thermostats and cold conductor motor winding in series!

**GB**

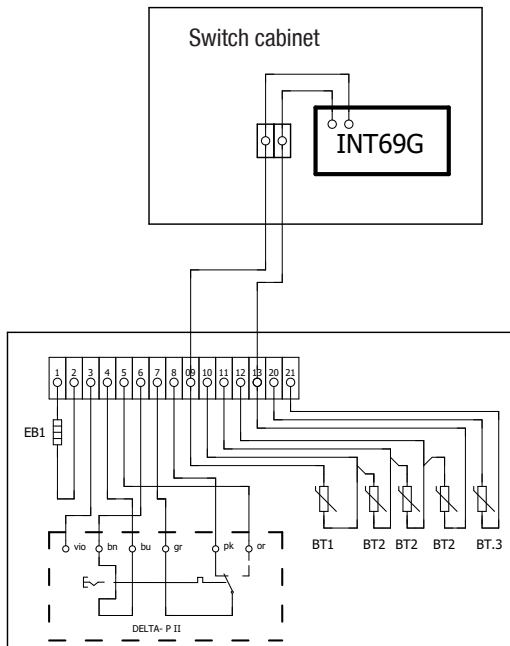

BT1	Cold conductor (PTC sensor) motor winding
BT2	Heat protection thermostat (PTC sensor)
BT3	Oil temperature sensor
EB1	Oil sump heater

Fig. 15

# 7 | Electrical connection

## 7.10 Oil sump heater (accessories)

When the compressor is at a standstill, refrigerant diffuses into the lubricating oil of the compressors housing, depending on pressure and ambient temperature. This reduces the lubricating capacity of the oil. When the compressor starts up, the refrigerant contained in the oil evaporates out through the reduction in pressure. The consequences can be foaming and migration of the oil, causing oil shocks under certain circumstances.

**Operation:** The oil sump heater operates when the compressor is at a standstill. When the compressor starts up, the oil sump heater switches off again automatically.

**Connection:** The oil sump heater must be connected via an auxiliary contact (or parallel wired auxiliary contact) of the compressor contactor to a separate electric circuit.

El. data: 230 V - 1 - 50/60 Hz, 160 W.

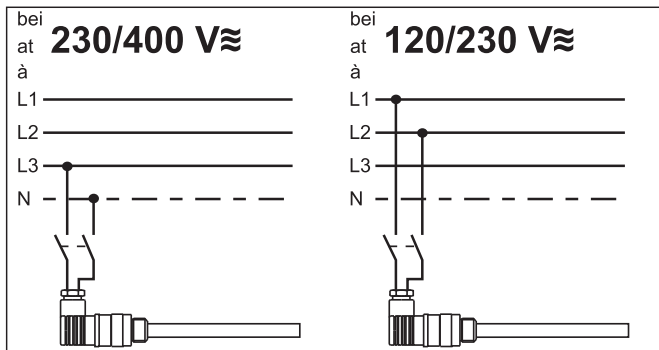

Fig. 16



**ATTENTION** Connection to the current path of the safety control chain is not permitted.

## 7.11 Oil sump heater on LG compressors

As the solubility of HFO refrigerants in oil can be very high, especially at high suction pressures, the compressor must be equipped with an oil sump heater. For this reason, a pump-down circuit is recommended during standstill to reduce the suction-side standstill pressures.

Electrical data: 230 V - 1 - 50/60 Hz, 160 W.



**ATTENTION** The oil sump heater must generally be connected and operated!

- In a TT- or TN system, a residual current protection device (RCD) must be used.
- In an IT system, an insulation monitoring device must be used.

**National standards and regulations must be observed.**

# 7 | Electrical connection

## 7.12 Capacity regulator (Accessories)



**ATTENTION** A fuse (max. 3xIB in accordance with IEC 60127-2-1) corresponding to the rated current must be placed in front of every magnetic coil of the capacity regulator as short-circuit protection. The rated voltage of the fuse must be equal to or greater than the rated voltage of the magnetic coil. The ability of the fuses to switch off must be greater than or equal to the maximum assumable short-circuit current at the installation location.

**Capacity regulator DCR14 is not approved for digital capacity regulation for LG compressors.**

## 7.13 Fan motor

The fan motor for cooling the compressor is already wired in the terminal box. The power supply as well as triggering of the compressor contactor should be made in accordance with the basic circuit diagram (in the terminal box). The fan motor is protected by an internal temperature monitor.

**Electrical data: 230 V - 1 - 50/60 Hz, 140 W - 0,71 A, IP44**

## 7.14 Selection and operation of compressors with frequency converters

For safe operation of the compressor, the frequency converter must be able to apply an overload of at least 140% of the compressor's maximum current (I-max.) for at least 3 seconds.

When using frequency converters, the following things must also be observed:

1. The maximum permissible operating current of the compressor (I-max) (see type plate or technical data) must not be exceeded.
2. If abnormal vibrations occur in the system, the affected frequency ranges in the frequency converter must be blanked out accordingly.
3. The maximum output current of the frequency converter must be greater than the maximum current of the compressor (I-max).
4. Carry out all designs and installations in accordance with the local safety regulations and common rules (e.g. VDE) and regulations as well as in accordance with the specifications of the frequency converter manufacturer

The permissible frequency range can be found in the technical data chapter 11.

<b>Rotational speed range</b>	0 - f-min	f-min - f-max
<b>Start-up time</b>	< 1 s	ca. 4 s
<b>Switch-off time</b>	immediately	

# 8 | Commissioning

## 8.1 Preparations for start-up



INFO

To protect the compressor against inadmissible operating conditions, high pressure and low pressure pressostats are mandatory on the installation side.

The compressor has undergone trials in the factory and all functions have been tested. There are therefore no special running-in instructions.

**Check the compressor for transport damage!**

## 8.2 Pressure integrity test

The compressor has been tested in the factory for pressure integrity. If however the entire system is to be subjected to a pressure integrity test, this should be carried out in accordance with EN 378-2 or a corresponding safety standard **without the inclusion of the compressor**.

## 8.3 Leak test



DANGER

**Risk of bursting!**

**The compressor must only be pressurised using nitrogen (N<sub>2</sub>). Never pressurise with oxygen or other gases!**

**The maximum permissible overpressure of the compressor must not be exceeded at any time during the testing process (see name plate data)! Do not mix any refrigerant with the nitrogen as this could cause the ignition limit to shift into the critical range.**

- Carry out the leak test on the refrigerating plant in accordance with EN 378-2 or a corresponding safety standard, while always observing the maximum permissible overpressure for the compressor.

## 8.4 Evacuation



ATTENTION

**Do not start the compressor if it is under vacuum. Do not apply any voltage - even for test purposes (must only be operated with refrigerant).**

Under vacuum, the spark-over and creepage current distances of the terminal board connection bolts shorten; this can result in winding and terminal board damage.

- First evacuate the **system** and then include **the compressor in the evacuation process**.
- Relieve the compressor pressure.
- Open the suction and pressure line shut-off valves.
- Evacuate the suction and discharge pressure sides using the vacuum pump.
- At the end of the evacuation process, the vacuum should be < 1.5 mbar when the pump is switched off.
- Repeat this process as often as is required.
- **For LG compressors suitable equipment approved for flammable refrigerants must be used.**

# 8| Commissioning

## 8.5 Refrigerant charge



**CAUTION** Wear personal protective clothing such as goggles and protective gloves!

- Make sure that the suction and pressure line shut-off valves are open.
- With the compressor switched off, add the liquid refrigerant directly to the condenser or receiver, breaking the vacuum.
- If the refrigerant needs topping up after starting the compressor, it can be topped up in vapour form on the suction side, or, taking suitable precautions, also in liquid form at the inlet to the evaporator.



**ATTENTION**

- **Avoid overfilling the system with refrigerant!**
- **To avoid shifts in concentration, zeotropic refrigerant blends must always only be filled into the refrigerating plant in liquid form.**
- **Do not pour liquid coolant through the suction line valve on the compressor.**
- **It is not permissible to mix additives with the oil and refrigerant.**

## 8.6 Start-up



**WARNING** Ensure that both shut-off valves are open before starting the compressor!

- Check that the safety and protection devices (pressure switch, motor protection, electrical contact protection measures, etc.) are all functioning properly.
- Switch on the compressor and let it run for at least 1 minute at a frequency of at least 50 Hz. Only then may the speed of the compressor be reduced.
- **Check the oil level by:** The oil must be visible in the sightglass.



**ATTENTION** If larger quantities of oil have to be topped up, there is a risk of oil hammer effects.  
If this is the case check the oil return!

GB

# 8 | Commissioning

## 8.7 Avoiding slugging



**ATTENTION** Slugging can damage the compressor and cause refrigerant to leak.

### To prevent slugging:

- The complete refrigeration system must be properly designed.
- All components must be compatibly rated with each other with regard to output (particularly the evaporator and expansion valves).
- Suction gas superheat at the compressor input **should be min. 7 - 10 K**. (check the setting of the expansion valve). For LG compressors see chapter 5.3.
- The system must reach a state of equilibrium.
- Particularly in critical systems (e.g. several evaporator points), measures are recommended such as replacement of liquid traps, solenoid valve in the liquid line, etc.

**There should be no movement of coolant whatsoever while the compressor is at a standstill.**

**The use of a check valve is strongly recommended. Otherwise, there is a risk of reverse condensation which may damage the compressor.**

GB

## 8.8 Connection of oil level regulator

Oil level regulation systems have proven themselves with parallel circuits of several compressors. The connection "O" is provided for installing an oil level regulator (see dimensions drawing). All common oil level regulators from AC&R, ESK and Carly as well as the OM3 TraxOil oil level regulation system from Alco can be connected directly without adapters (see Fig. 17). A sight glass on the oil level regulator is not required.

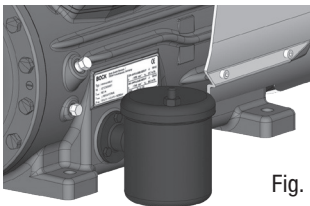
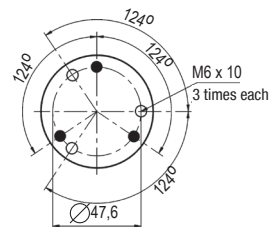

Fig. 17

Mechanical oil level regulator at the "O" connection



- 3 hole connection diagram for ESK, AC&R and CARLY
- 3 hole diagram for TraxOil

# 9| Maintenance

## 9.1 Preparation



### WARNING

Before starting any work on the compressor:

- Switch off the compressor and secure it to prevent a restart.
- Relieve compressor of system pressure.
- Prevent air from infiltrating the system!

After maintenance has been performed:

- Connect safety switch.
- Evacuate compressor.
- Release switch lock.

## 9.2 Work to be carried out

In order to guarantee optimum operational reliability and service life of the compressor, **we recommend** carrying out servicing and inspection work at regular intervals:

### ● Oil change:

- not mandatory for factory-produced series systems.
- for field installations or when operating near the application limit: for the first time after 100 to 200 operating hours, then approx. every 3 years or 10,000 - 12,000 operating hours. Dispose of used oil according to the regulations; observe national regulations.

- **Annual checks:** Oil level, leak tightness, running noises, pressures, temperatures, function of auxiliary devices such as oil sump heater, pressure switch.

GB

## 9.3 Condensate drainage

The terminal box has the option for Condensate drainage (see Fig. 18).



### ATTENTION

When the condensate drain is used, the protection rating of the terminal box is reduced from IP65 to IP32!

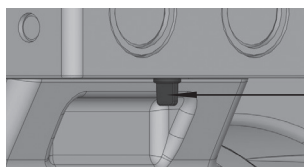

Condensate drainage

Fig. 18

# 9 | Maintenance

## 9.4 Spare parts recommendation/accessories

Available spare parts and accessories can be found on our compressor selection tool under [vap.bock.de](http://vap.bock.de) as well as at [bockshop.bock.de](http://bockshop.bock.de).

**Only use genuine Bock spare parts!**

## 9.5 Lubricants / oil

The oil type filled as standard in the factory is marked on the **name plate**, and this should always be used, even in the case of maintenance units. **Alternative oil types** can vary significantly in quality due to additives or inferior raw materials by the manufacturer. Validation within the compressors entire operating limits can not be guaranteed, if such alternative oil types are used. It is for this reason, that we only recommend the use of oil from Bock! Bock assumes no liability for any damage arising from alternative oil types.

Refrigerants	Bock standard oil types
<b>HFC</b> (e.g. R134a, R407C)	<b>BOCK</b> lub E55
<b>HFO</b> (e.g. R455A, R454C)	<b>BOCK</b> lub E55
<b>HCFC</b> (e.g. R22)	<b>BOCK</b> lub A46

GB

## 9.6 Decommissioning

Close the shut-off valves on the compressor. Drain the refrigerant (it must not be discharged into the environment) and dispose of it according to the regulations. When the compressor is depressurised, undo the fastening screws of the shut-off valves. Remove the compressor using an appropriate hoist. Dispose of the oil inside in accordance with the applicable national regulations.

## 9.7 Additional information when using flammable refrigerants



### WARNING

- During maintenance and repair, it must be noted that HFO refrigerants residues may dissolve in the oil. Therefore, electrical tests must not be conducted while oil remains in the compressor.
- If the compressor is to be removed from the system for maintenance or repair, the remaining refrigerant must be suctioned out and the compressor evacuated. The compressor must then be filled with nitrogen (max. 0.5 bar) and sealed gas-tight.

# 10|Accessories

## 10.1 Capacity regulator



**ATTENTION** If the capacity regulator is installed at the factory, it is subsequently installed and connected by the customer.

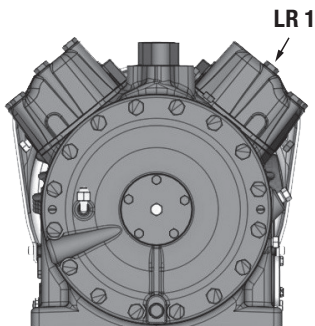

Fig. 19

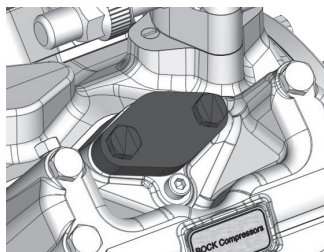

Fig. 20

Delivery condition 1 (from the factory):  
Cylinder cover prepared for capacity regulator.

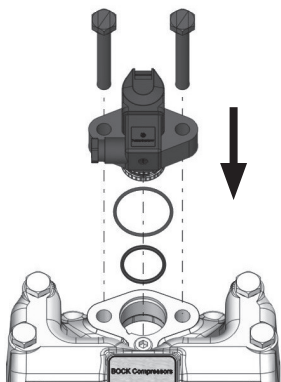

Fig. 21

Before commissioning, the blind flange with screws must be removed and replaced by the new set capacity regulator with O-ring joints and screws. Observe position and construction of the capacity regulator.

**Attention! Compressor is under pressure!**  
**Depressurize the compressor first.**

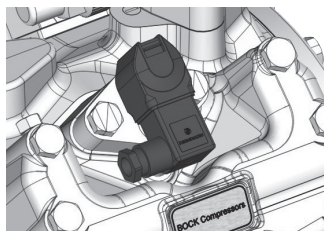

Fig. 22

Delivery condition 2 (from the factory):  
Connect capacity regulator in terminal box or switch cabinet.



**WARNING** Several capacity regulators cannot switch at the same time during compressor operation! Otherwise the sudden change in load can damage the compressor! Comply with the switching interval of 60 s.

- Comply with the switching sequence:  
Switching on LR1 — 60s —> LR2  
Switching off LR2 — 60s —> LR1

# 10 | Accessories



## ATTENTION

- **Capacity-regulated operation alters the gas speeds and pressure ratios of the refrigerating plant: Adjust the suction line routing and dimensioning accordingly, do not set the control intervals too close and do not let the system switch more than 12 times per hour (refrigerating plant must have reached a state of equilibrium). Continuous operation in the control stage is not recommended as the gas velocity in the plant system under certain circumstances does not guarantee sufficient oil return to the compressor with activated capacity regulator.**

**We recommend switching to unregulated operation (100% capacity) for at least 5 minutes per capacity-regulated operating hour. An assured oil return can also be realised by a 100% capacity requirement after each compressor restart.**

- **Electrical actuation of the solenoid valve: Normally open, (corresponds to 100 % compressor capacity).**

Special accessories are only premounted in the factory if ordered specially by customer. Retrofitting is possible in full compliance with the safety instructions and repair instructions enclosed with the kits. Information about the use, operation, maintenance and servicing of the components is available in the printed literature or on the internet under [www.bock.de](http://www.bock.de).

GB

For the capacity regulator a step protection is optional available, Art-Nr. 097B81449.

Please note that the legacy BOCK ref. numbers are without 097B.

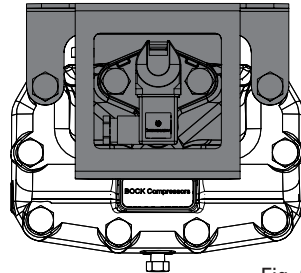

Fig. 23

# 11 | Technical data

Oil charge (sight glass centre)		litr		2.3	
Oil charge (ex works)		litr		2.7	
Connections <sup>④</sup>	Suction line SV	mm (inch)		35 (1 3/8)	
	Discharge line DV	mm (inch)		28 (1 1/8)	
Weight		kg	174	178	
Electrical data <sup>③</sup>		permissible frequency range	Hz	25 - 70	
Starting current (rotor locked)	PW 1 / PW 1+2		A	87 / 149	
	Max. power consumption	<sup>②</sup>	kW	7,6	
Max. operating current <sup>②</sup>	PW 1+2		A	15,2	
	Voltage	<sup>①</sup>	V	380-420 V Y/YY - 3 - 50 Hz PW 440-480 V Y/YY - 3 - 60 Hz PW PW = Part Winding Winding ratio : 50 % / 50 %	
Displacement (1450 / 1740 rpm)		50 / 60 Hz		m <sup>3</sup> /h	41,3 / 49,6
	No. of cylinders				49,2 / 59,0
Type*		HA44e/			57,7 / 69,3
					475-4
					565-4
					665-4

\* The technical data for LG compressors are identical to the standard compressors. Therefore, these designations are not included in the compressor type specification.

<sup>①</sup> Tolerance ( $\pm 10\%$ ) relative to the mean value of the voltage range.

<sup>②</sup> Other voltages and types of current on request.

<sup>③</sup> - The specifications for max. power consumption apply for 50Hz operation.

<sup>④</sup> For 60Hz operation, the specifications have to be multiplied by the factor 1.2.

The max. working current remains unchanged.

- Take account of the max. operating current / max. power consumption for

design of fuses, supply lines and safety devices.

Fuse: Consumption category AC3

<sup>③</sup> All specifications are based on the average of the voltage range

<sup>④</sup> For solder connections

# 12 | Dimensions and connections

**HA44e**

(Dimensions and connections for LG compressors are identical to the standard compressors)

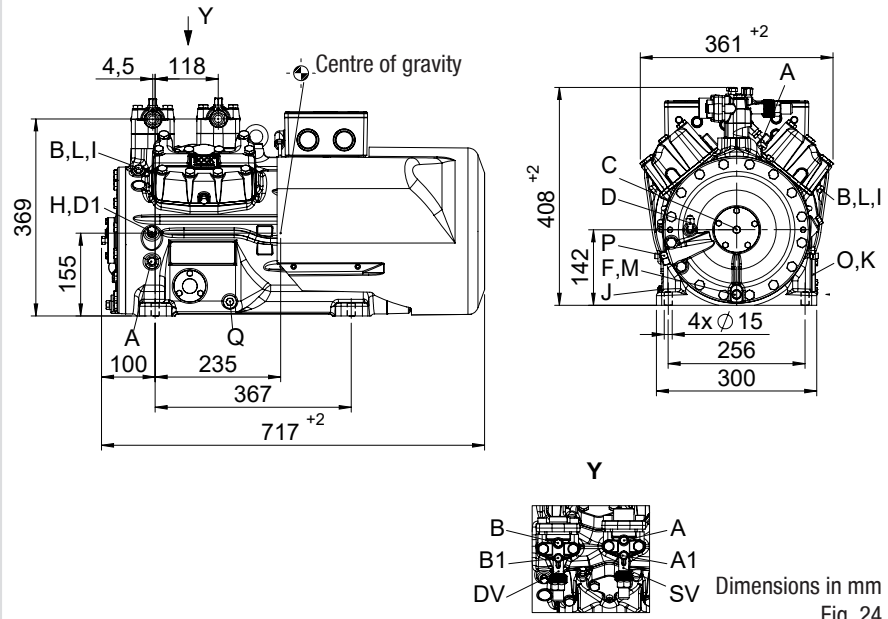

**GB**

Dimensions in mm  
Fig. 24

<b>SV</b>	Suction line	see technical data, Chapter 11	
<b>DV</b>	Discharge line		
<b>A</b>	Connection suction side, not lockable		1/8" NPTF
<b>A1</b>	Connection suction side, lockable		7/16" UNF
<b>B</b>	Connection discharge side, not lockable		1/8" NPTF
<b>B1</b>	Connection discharge side, lockable		7/16" UNF
<b>D</b>	Connection oil pressure switch LP		7/16" UNF
<b>D1</b>	Connection oil return from oil separator		1/4" NPTF
<b>E</b>	Connection oil pressure gauge		1/8" NPTF
<b>F</b>	Oil drain		M12 x 1,5
<b>H</b>	Oil charge plug		1/4" NPTF
<b>I</b>	Connection hot gas temperature sensor		1/8" NPTF
<b>J</b>	Connection oil sump heater		3/8" NPTF
<b>K</b>	Sight glass		3 x M6
<b>L</b>	Connection thermal protection thermostat		1/8" NPTF
<b>M</b>	Oil strainer		M12 x 1,5
<b>O</b>	Connection oil level regulator		3 x M6
<b>P</b>	Connection oil pressure differential sensor		M20 x 1,5
<b>Q</b>	Connection oil temperature sensor		1/8" NPTF

# 13 | Declaration of incorporation

## Declaration of incorporation for incomplete machinery in accordance with EC Machinery Directive 2006/42/EC, Annex II 1. B

Manufacturer: Bock GmbH  
Benzstraße 7  
72636 Frickenhausen, Germany

We, as manufacturer, declare in sole responsibility that the incomplete machinery

Name: Semi-hermetic compressor  
Types: HG(X)12P/60-4 S (HC) ..... HG(X)88e/3235-4(S) (HC)  
UL-HGX12P/60 S 0,7 ..... UL-HGX66e/2070 S 60  
HGX12P/60 S 0,7 LG ..... HGX88e/3235 (ML/S) 95 LG  
HG(X)22(P)(e)/125-4 A ..... HG(X)34(P)(e)/380-4 (S) A  
HGX34(P)(e)/255-2 (A) ..... HGX34(P)(e)/380-2 (A)(K)  
HA(X)12P/60-4 ..... HA(X)6/1410-4  
HAX22e/125 LT 2 LG ..... HAX44e/665 LT 14 LG  
HGX12e/20-4 (ML/S) CO<sub>2</sub> (LT) ..... HGX44e/565-4 S CO<sub>2</sub>  
UL-HGX12e/20 (S/ML) 0,7 CO<sub>2</sub> (LT)... UL-HGX44e/565 S 31 CO<sub>2</sub>  
HGX12/20-4 (ML/S/SH) CO<sub>2</sub>T ..... HGX46/440-4 (ML/S/SH) CO<sub>2</sub> T  
UL-HGX12/20 ML(P) 2 CO<sub>2</sub>T ..... UL-HGX46/440 ML(P) 53 CO<sub>2</sub>T  
HGZ(X)7/1620-4 ..... HGZ(X)7/2110-4  
HGZ(X)66e/1340 LT 22 ..... HGZ(X)66e/2070 LT 35  
HRX40-2 CO<sub>2</sub> T H ..... HRX60-2 CO<sub>2</sub> T H

Name: Open type compressor  
Types: F(X)2 ..... F(X)88/3235 (NH3)  
FK(X)1 ..... FK(X)3  
FK(X)20/120 (K/N/TK) ..... FK(X)50/980 (K/N/TK)

Serial number: BC00000A001 – BN99999Z999

complies with the following provisions of the above-mentioned Directive:

According to Annex I, points 1.1.2, 1.1.3, 1.1.5, 1.3.2, 1.3.3, 1.3.7, 1.5.1, 1.5.2, 1.5.13 and 1.7.1 to 1.7.4 (excepted 1.7.4 f) are fulfilled.

Applied harmonised standards, in particular:

EN ISO 12100 :2010 Safety of machinery — General principles for design — Risk assessment and risk reduction  
EN 12693 :2008 Refrigerating systems and heat pumps — Safety and environmental requirements — Positive displacement refrigerant compressors

Remarks: We also declare that the special technical documentation for this incomplete machine has been created in accordance with Annex VII, Part B and we obligate to provide these upon reasoned request from the individual national authorities by data transfer.

Commissioning is prohibited until it has been confirmed that the machinery into which the incomplete machine above is to be incorporated complies with the EC Machinery Directive and an EC Declaration of Conformity, Annex II. 1. A exists.

Authorized person for compiling and handing  
over technical documentation:

Bock GmbH  
Alexander Layh  
Benzstraße 7  
72636 Frickenhausen, Germany

Frickenhausen, 04th of January 2021



i. A. Alexander Layh, Global Head of R&D

GB

# 13 | Declaration of incorporation

## Declaration of incorporation of partly completed machinery in accordance with UK Statutory Instrument Supply of Machinery (Safety) Regulations 2008, Annex II 1. B

Manufacturer: Bock GmbH  
Benzstraße 7  
72636 Frickenhausen, Germany



We, as manufacturer, declare in sole responsibility that the partly completed machinery

Name: Semi-hermetic compressor  
Types: HG(X)12P/60-4 S (HC) ..... HG(X)88e/3235-4(S) (HC)  
UL-HGX12P/60 S 0,7 ..... UL-HGX66e/2070 S 60  
HGX12P/60 S 0,7 LG ..... HGX88e/3235 (ML/S) 95 LG  
HG(X)22(P)(e)/125-4 A ..... HG(X)34(P)(e)/380-4 (S) A  
HGX34(P)(e)/255-2 (A) ..... HGX34(P)(e)/380-2 (A)(K)  
HA(X)22e/125-4 ..... HA(X)6/1410-4  
HAX22e/125 LT 2 LG ..... HAX44e/665 LT 14 LG  
HGX12e/20-4 (ML/S) CO<sub>2</sub> (LT) ..... HGX44e/565-4 S CO<sub>2</sub>  
UL-HGX12e/20 (S/ML) 0,7 CO<sub>2</sub> (LT)... UL-HGX44e/565 S 31 CO<sub>2</sub>  
HGX12/20-4 (ML/S/SH) CO<sub>2</sub>T ..... HGX46/440-4 (ML/S/SH) CO<sub>2</sub> T  
UL-HGX12/20 ML(P) 2 CO<sub>2</sub>T ..... UL-HGX46/440 ML(P) 53 CO<sub>2</sub>T  
HGZ(X)7/1620-4 ..... HGZ(X)7/2110-4  
HGZ(X)66e/1340 LT 22 ..... HGZ(X)66e/2070 LT 35  
HRX40-2 CO<sub>2</sub> T H ..... HR(Z)X60-2 CO<sub>2</sub> T (H)(V)

Name: Open type compressor  
Types: F(X)2 ..... F(X)88/3235 (NH3)  
FK(X)1 ..... FK(X)3  
FK(X)20/120 (K/N/TK) ..... FK(X)50/980 (K/N/TK)

Serial number: BC0000A001 – BN99999Z999

complies with the following provisions of the above-mentioned Statutory instrument:

According to Schedule 2, part1, points 1.1.2, 1.1.3, 1.1.5, 1.3.2, 1.3.3, 1.3.7, 1.5.1, 1.5.2, 1.5.13 and 1.7.1 to 1.7.4 (excepted 1.7.4 f) are fulfilled.

Designated standards: EN ISO 12100 :2010 Safety of machinery — General principles for design — Risk assessment and risk reduction  
EN 12693 :2008 Refrigerating systems and heat pumps — Safety and environmental requirements — Positive displacement refrigerant compressors

Remarks: We also declare that the special technical documentation for this partly completed machine has been created in accordance with Annex II, 1. B and we obligate to provide these upon reasoned request from the individual national authorities by data transfer.

Commissioning is prohibited until it has been confirmed that the machinery into which the partly completed machine above is to be incorporated complies with the UK Statutory Instrument Supply machinery (Safety) regulations 2008 and an EC Declaration of Conformity, Annex II, 1. A exists.

Authorized representative for compiling and handing over technical documentation:

UKCA Experts Ltd.  
Dept 302, 43 Owston Road  
Carcroft, Doncaster, DN6 8DA,  
United Kingdom

Frickenhausen, 14th of October 2022

i. A. Alexander Layh, Global Head of R&D



ENGINEERING  
TOMORROW



**Danfoss A/S**  
Climate Solutions • danfoss.com • +45 7488 2222

Any information, including, but not limited to information on selection of product, its application or use, product design, weight, dimensions, capacity or any other technical data in product manuals, catalogues descriptions, advertisements, etc. and whether made available in writing, orally, electronically, online or via download, shall be considered informative, and is only binding if and to the extent, explicit reference is made in a quotation or order confirmation. Danfoss cannot accept any responsibility for possible errors in catalogues, brochures, videos and other material. Danfoss reserves the right to alter its products without notice. This also applies to products ordered but not delivered provided that such alterations can be made without changes to form, fit or function of the product.  
All trademarks in this material are property of Danfoss A/S or Danfoss group companies. Danfoss and the Danfoss logo are trademarks of Danfoss A/S. All rights reserved.